



OWNER'S MANUAL

AARDWOLF

MONO MECHANICAL VACUUM LIFTER

AMMVL150



No power source required. Ideal for the horizontal handling of non-porous sheet and plate materials such as diamond sawn or polished granite, engineered stone, all types of metals, plastics and fiberglass. An automatic self-cycling valve located at the bottom of the piston controls the vacuum grip-and-release cycle.

A handle (sold separately) is manually employed by two persons for easy transportation.

OPERATING INSTRUCTIONS

BEFORE OPERATING THE LIFTER

- **Attaching the lifter to hoisting equipment**

- Determine the capacity of hoisting equipment (crane and hoist, when applicable) that is fit with the maximum load weight plus the lifter weight.
- Determine the sling that is fit with the maximum load weight plus the lifter weight.
- Perform the load test, vacuum test for the lifter before handling the load.
- Inspect the lifter for damage that may have occurred during shipping.
- While unpacking, make sure the components are intact & their quantity is correct.
- Make sure there are no kinks in the flexible vacuum conduit
- Re connect/assemble all items disconnected for shipping purposes before using.
- Check all fasteners for tightness. Vibration during shipping can loosen screws & bolts.
- Remove all packing material. Make sure the underside of sealing ring is clean & free of debris.
- Make sure that there are no kinks in the flexible vacuum conduit.
- All manual shut-off valves are in the open position.
- The shackle/master link is not twisted when hanging the unit on the crane hook.
- Lift this unit only by the chain master link.
- All position locking knobs or wing nuts are tight and pads and/ or cross arms are correctly positioned.
- All hoses, handle bar, alarm battery etc. are disconnected for shipping purposes.
Please reconnect/ assemble all such items before using.
- Read the instruction and service manual.
- Make certain all operating personnel are familiar with the operating procedures and safe lifting practices, as well as understanding all the laws, rules and regulations applicable for below-the-hook lifting devices.
- It is important to ensure that regular examinations and inspections of lifting gear are undertaken to ensure maintenance is kept, and to verify that the equipment can continue to be safely used.
- Lifting gear inspections must be undertaken on a regular basis, by a person with adequate training, knowledge, skills and expertise

- **Safety instruction**

- Remember that proper lifting knowledge and techniques are the responsibility of operator. Be sure to read and understand the instructions and safety warnings contained in this manual before using your vacuum lifter.
- If you do not understand everything in this manual, contact Aardwolf Industries LLC for assistance before using the lifter.

OPERATING INSTRUCTIONS

- Keep the lifter in a good condition and carry out the maintenance schedule established by the manufacturer.
- Keep the lifter clean and dry, and free from debris. Clean up loose dirt accumulated on surface and especially on the rubber dust cover that is visible from the top.
- Once a week, inspect vacuum seal on lifter to make sure that the sealing surface and especially the inner sealing ridge is intact and clean. If inner sealing ridge is damaged, replace seal. Damaged or cut seals are dangerous.
- Make sure no debris is trapped between seal and flange of vacuum pads or lifter.
- Once a week, check the vacuum loss sensor and warning device with test switch to make sure the horn and lights operate correctly. The low battery indicator will cause the horn and the LED active intermittently when battery power is low. Replace batteries when necessary.
- Once every month, check vacuum gauge(s) to make sure the dial uninterruptedly travels and the capacity indication is clearly visible.
- Once every month, check vacuum lifter on vacuum holding by lifting a test load of absolutely clean, flat, rigid and absolutely clean, flat, rigid material and note the amount of vacuum obtained at the start of the lift. To cancel any possible vacuum leakage due to an imperfect load surface, make load surface wet with water.
- Continue to test for one quarter hour and record holding vacuum at the end of test. If a drop in holding vacuum is less than 15% of initial vacuum, the lifter is in satisfactory condition for use. If vacuum drop is in excess of 15%, the lifter is unsafe and should be checked to locate the reason for vacuum loss.
- Once every month inspect vacuum lines, vacuum tube clamps, valves, fitting and pad suspensions for damage and abnormal wear. Tighten all clamps and fittings and replace damaged or worn parts. Check air inlet valve on top of cylinder cover to make sure valve disc is loose.
- If any other malfunctions are observed, check your trouble shooting guide or contact Aardwolf Industries LLC for service.

- **Dos and Don'ts for operator's safety**

Dangers always exist when loads are transported by lifting devices, especially if the equipment is not being used properly or is poorly maintained. Because accidents and severe bodily injury or death can result, special safety precautions apply to the operation, inspection and the maintenance of the vacuum lifter. Please read attentively Dos and Don'ts for your safety and long-time life of lifter.

- Besides being properly trained and instructed on how to operate the equipment, operators should have specific abilities and skills for the type of work to be carried out and should be in suitable conditions to avoid any risks to people's safety and health, as well as to avoid any commercial damage.

OPERATING INSTRUCTIONS

- Do not operate lifter without inspection and testing prior to each shift.
- Report any unusual operation or safety concerns to a qualified person and discontinue use of the vacuum lifting device until safety has been assured.
- Do not use vacuum lifting device with an "Out of Order" tag until it returned to proper operating condition.
- Do not use lifter if capacity or safety markings are missing.
- Do not use the equipment if the safety devices are not perfectly installed and working efficiently.
- Make sure that supporting structure and load-attaching devices (.e. crane, chain, and hook) are rated to support the weight of the lifter and load.
- Be sure to subtract the weight of the lifter from crane or hoist capacity when calculating the actual net capacity of the system.
- Use lifter only on non-porous smooth loads.
- De-rate load capacity by 3.5% for each 1000 ft. of elevation above sea level.
- Use lifter only on loads with clean surface; brush of loose debris, dirt, scale, chips, etc
- Do not use lifter on; pad with the badly rusted, pitted, or scaled surface. Never lift loads weighted more than rated lifting capacity.
- Do not use lifter on loads that exceed recommended length and width for a particular thickness. Consult load overhang tables contained in this manual.
- Do not lift more than one work piece at a time. If sheets are sticky, place the load down immediately and split sheets into each single one prior to lifting.
- Use the equipment only for the tasks authorized by the manufacturer. Any unintended use can put people's safety and health at risk and threaten commercial damage.
- Use lifter only for horizontal lifting and free of overhead transportation. Do not use lifter to drag loads over floors.
- Use the handlebars to position the lifter and guide the load.
- Do not push or pull the load with your hands on the load.
- Accelerate and decelerate loads smoothly.
- Avoid contact of loads with obstructions.
- When adjusting cross arms and pads, keep vacuum lines free of twists and kinks.
- Do not pinch the vacuum lines.
- While applying the devices onto the material, make sure the grip is properly executed. Carry out the handling without lifting the equipment too high from the ground, avoid any abrupt movement and keep yourself at a safe distance.
- Do not lift loads higher than necessary.
- Prevent the outsiders from staying too close to the operating area while the equipment is being used. If necessary, stop the equipment operation immediately and keep everybody away from the working area.

OPERATING INSTRUCTIONS

- Do not tilt any load more than 15° from horizontal. Never lift excessively wet or oily loads.
- Do not use lifter on loads less than 10% of rated capacity for single pad lifters.
- Always stay clear of the load. Do not place your feet or hands under the load.
- Keep your face and body away from lifter or load in event of accidental release.
- Do not keep loads suspended for unnecessarily long periods, such as during coffee or lunch breaks or other work stoppage.
- Do not stand under suspended loads or lift loads over people.
- Be sure to inform those near you that a lifting operation is about to begin.
- Check all fasteners for tightness. Vibration during shipping can loosen screws and bolts.
- All position locking knobs or wing nuts are tight and pads and/or cross-arms are correctly positioned.
- The shackle/master link is not twisted when hanging the unit on the crane hook.
- During operation always wear the individual protection clothing and/or devices indicated in the operating instructions supplied by the manufacturer and those provided by the applicable legislation concerning safety at the workplace.

- **How mechanical vacuum lifter work?**

Upward/downward movement controls vacuum pickup and release. Simply on/off cycle is quick and reliable.

Raising the hoist hook and piston creates a vacuum in chamber formed by piston bottom, cylinder walls and load surface.

Flexible vacuum sealing ring around bottom ange seals out outside air. Vacuum secures powerful “bond” between lifter and load which now can be lifted. When the load and lifter are lowered, piston descends in cylinder. At lowest point the piston valve opens and lifter can be released from load, ready for next pick-up.

- **Basic Operating Procedure**

1. Lower lifter onto load until the shackle/master link is slack.
2. Raise hoist to lift shackle/master link and internal piston to create vacuum.
3. Vacuu pad of lifter attaches and lifts the load.
4. Transport the load to the expected location.
5. Lower the hoist until shackle/master link is slack again.
6. Internal valve now makes a cycle route to release the vacuum and detach the load.
7. Lifter may now be raised slowly until the load is released.

- **Technical description**

- The vacuum generator of the Aardwolf lifter consists of a free-moving piston within a closed cylinder. A rubber rolling diaphragm forms an airtight seal between piston and cylinder. Since the integrity of this seal does not depend on metal-to-metal contact, it does not lose efficiency in operation.
- When the load is completely set down and the shackle/ master link is again slackened, the cam opens the piston valve, releasing the vacuum. The lifter then can be raised, ready for the next pickup.
- The operation of grip and release is instantaneous. Since the valve can only cycle when the shackle/master link is completely slack, it cannot be shifted to the “release” position while a load is being held.

SECTION OF MECHANICAL VACUUM LIFTER - AMMVL150

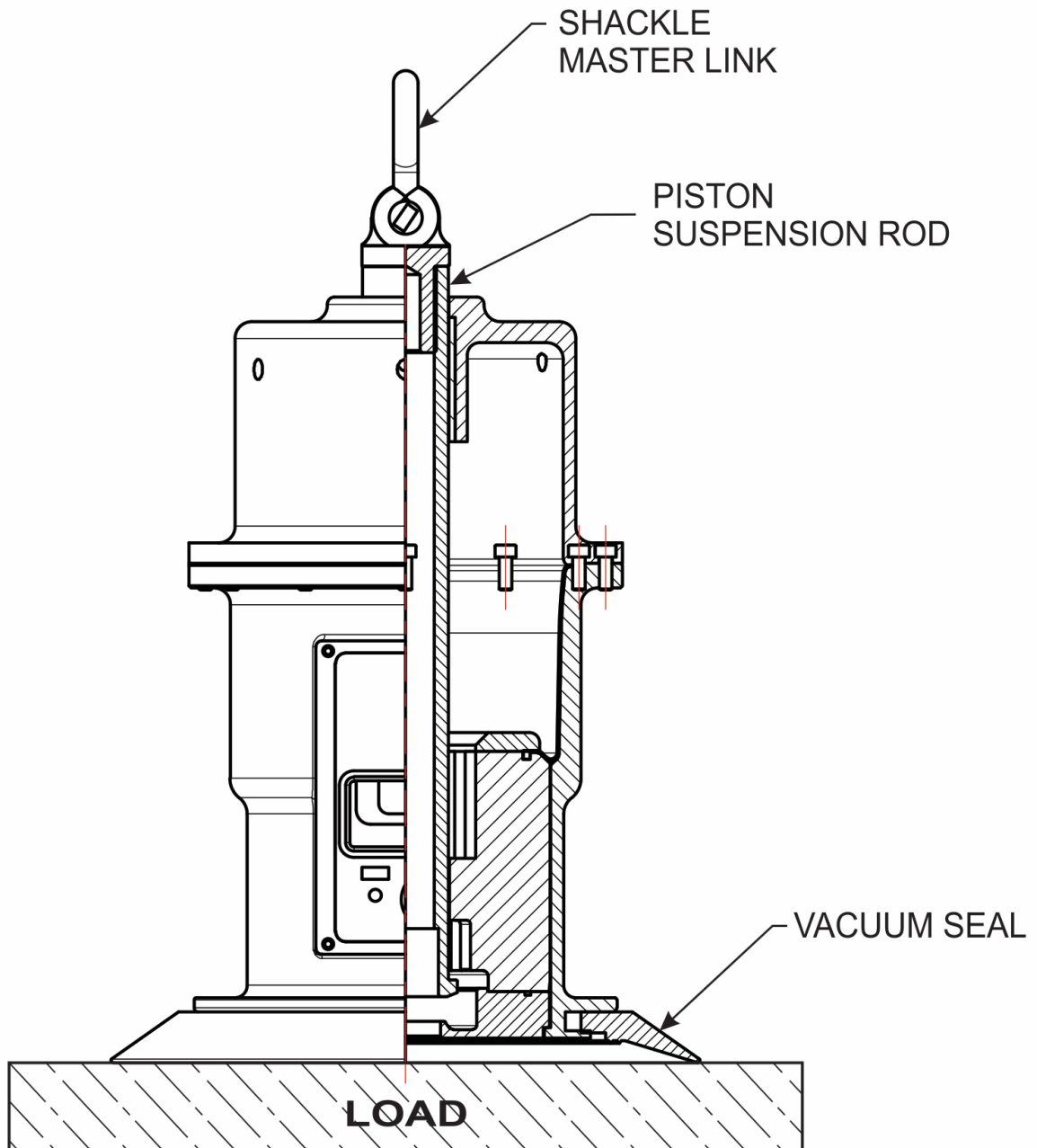

- Hook suspended lifter is placed on load piston descends to lowest position, piston valve closes, weight of lifter compresses vacuum seal between bottom flange and load surface.
- The vacuum grip and release cycle is controlled by an automatic self-cycling valve located in the bottom of the piston. When the unit is lowered onto the load and the shackle/master link slackens, a cam automatically closes the piston valve. Hoisting action then pulls up the piston, creating a powerful vacuum inside the cylinder and underneath the vacuum pads.

- **How safe is vacuum handling?**

Vacuum uses the unfailing atmospheric pressure as a source of power and this energy source is totally safe and reliable.

The vacuum between a vacuum pad and the surface of a suitable load which was held in place by a rubber seal compressed between pad and load, will never fail to 'hold' the load unless the vacuum is reduced by a leakage of air of the gap between the pad and the load surface.

All "powered" vacuum lifters that generate vacuum with pumps or venturis must rely on an outside power source. The vacuum lifters will generally have vacuum leakage warning devices to detect leakage and vacuum reserve tanks to decrease the effects of leaks.

The greatest source of mishaps or failures with vacuum handling equipment occurs with misapplication and human failure. A vacuum lifter is a specialized lifting tool and should not be treated as a generalpurpose handler to be operated by untrained labor on any and all loads.

(For detailed recommendations for safe vacuum handling, always refer to the vacuum lifter instruction manual and comply with all the laws, rules and regulations applicable to your country).

However, when operated as recommended by the suppliers of vacuum lifters, these system have been proven to be extremely safe for operators and floor personnel as no one needs to get close to the load and no hands are required to attach and detach the load.

NOTE

1. The end user should check all spare parts based on the spare part list and ensure that no items has been damaged or lost during shipment. In event of lack or damage of any items, immediately inform the distributor or seller within 8 days since the date of good receipts.
2. The assembly of lifter should be carried out by only competent person who has been familiar with the lifters.
3. Aardwolf Industries LLC's warranty does not cover any claims due to incorrect assembly by an incompetent person or replacement of non-original items or failures to conformity of manufacturer's manual.

DRAWING LIST

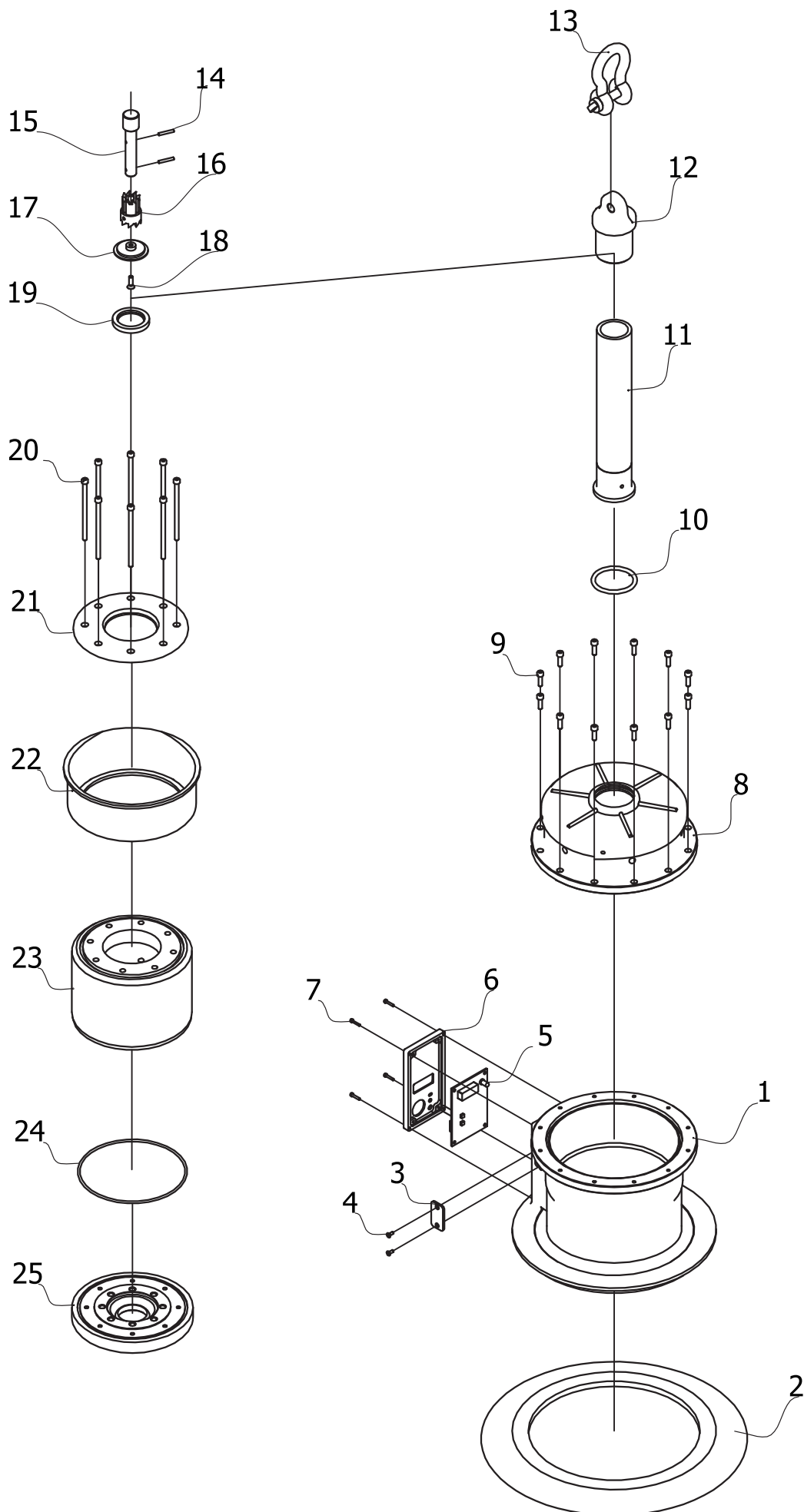

PARTS LIST

POS.	CODE	DESCRIPTION	Q'TY
01	AMMVL150-001	Housing	01
02	AMMVL150-002	Seal 250	01
03	AMMVL150-003	Cover battery	01
04	AMMVL150-004	Bolt M3 x 12	02
05	AMMVL150-005	Circuit	01
06	AMMVL150-006	Cover box	01
07	AMMVL150-007	Bolt M5 x 12	04
08	AMMVL150-008	Top housing	01
09	AMMVL150-009	Bolt M6 x 25	12
10	AMMVL150-010	O - ring 60 x 50 x 5	01
11	AMMVL150-011	Main Splinder	01
12	AMMVL150-012	Hook	01
13	AMMVL150-013	Shackle	01
14	AMMVL150-014	Pin 4	02
15	AMMVL150-015	Valve shaft	01
16	AMMVL150-016	Valve lock	01
17	AMMVL150-017	Valve plate	01
18	AMMVL150-018	Recessed pan head screw M6x12	01
19	AMMVL150-019	Rubber cover valve	01
20	AMMVL150-020	Bolt M6 x 110	08
21	AMMVL150-021	Top piston	01
22	AMMVL150-022	Piston diaphragma	01
23	AMMVL150-023	Middle piston	01
24	AMMVL150-024	O-ring 118 x 123 x 2.5	01
25	AMMVL150-025	Bottom piston	01

SPECIFICATIONS

- With swivel hook

AMMVL150	Metric	Imperial
Pad diameter	200 mm	8 in
Working load limit	150 kg	331 lb
Net weight	12 kg	26 lb
Gross weight	16 kg	35 lb
Packaging dimensions	320 x 320 x 390 mm	12.6 x 12.6 x 15.3 in

- With handle hook

AMMVL150	Metric	Imperial
Working load limit	150 kg	331 lb
Net weight	14 kg	31 lb
Package weight	23 kg	51 lb
Packaging dimensions	830 x 280 x 570 mm	32.7 x 11 x 22.4 in

- **Battery information for the alarm system**
 - Power supply : 9 V non-rechargeable
 - 6-month warranty

FEATURES

- Self-powered and self-cycling.
- Audio alarm system powered by a non-rechargeable 9V battery.
- Immediately ready for operation.
- Low maintenance.
- Aluminum construction.
- Lightweight.

INSTRUCTIONS FOR USE

1. Make sure that the vacuum lifter is compatible with the equipment capacity.
2. Make sure that the operating area offers an appropriate maneuvering space and suitable environmental conditions.
3. While lifting, the vacuum gauge should be facing operator. For all lifters with a vacuum leakage sensor and warning device, test the signal with the test switch provided.
4. To start lifting, put the lifting master link into the hoist hook, center the lifter correctly on the load, and make sure shackle/master link suspension is straight and not twisted or kinked.
5. Make sure vacuum pads are evenly spaced over the length and width of the load. Observe the load overhang tables in this manual.
6. Push and press “Push to Test” button to check if battery, light and horn are operable before each lift. If horn and light are intermittently active, regard less with or without vacuum, it indicates low level of battery, it is time to replace a new 9V Lipo battery.
7. When ready for lifting, raise hoist or crane hook slowly to obtain initial vacuum grip. If no vacuum is generated, lifter is in release cycle. Lower hook, slacken chain and repeat cycle.
8. When vacuum is obtained, and lifter starts raising the load, stop the crane or hoist and make sure that the holding vacuum is stable and that the load is balanced. If the dial on the vacuum gauge slowly travels to zero, you have an unsafe vacuum grip possibly due to an imperfect vacuum seal or an equipment malfunction. Lower the hook, check the seal, re-position the lifter and repeat the cycle. If lifter continues to leak, consult the trouble shooting procedures in this manual. If holding vacuum appears stable, continue to lift.
9. If the vacuum leakage sensor is activated while the load is suspended, put the load down and determine the reason for vacuum leakage.
10. When ready to put load down, lower the hook until the lifter shackle/master link suspension is slacken completely. Now raise the hook of crane or hoist and the lifter can be lifted from the load.

CAUTION: Residual vacuum can be present at the vacuum pads. Lift slowly until pads are free from the load.

DISPLAY PANEL & UNIT

The Vacuum Leakage Sensor & Warning System provides key information for safe lifting.

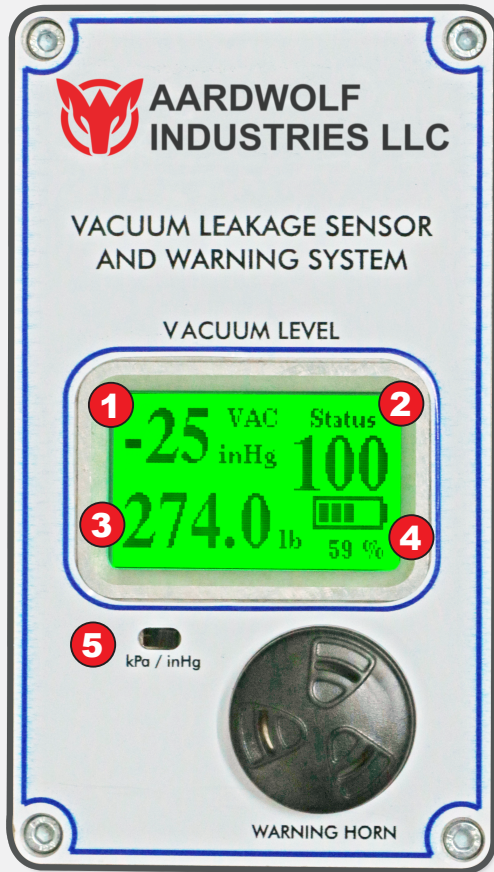

- 1 Vacuum Pressure Indicator (in kPa or inHg)
- 2 Vacuum Percentage (%)
- 3 Weight of Load (in Kg or lb)
- 4 Display Battery Percentage
- 5 Vacuum Pressure Unit Switch (kPa ↔ inHg)



INSPECTIONS AND MAINTENANCE

• STORAGE OF LIFTER

1. When the lifter is not being used, do not leave it suspended from the hook. Put it down on its parking stand. (Leaving lifter suspended for long periods without a load can cause damage to the internal diaphragm). It is best to store the lifter with the vacuum pad sealing edges in their free state, supported off the floor.
2. Keep the slide valve in the “**OFF**” position when not in operation. Disconnect the lifter from the power source. Disconnect the charging power plug after the battery is fully recharged
3. Store lifter inside. Clean the vacuum lifter and the whole equipment from any debris. Avoid any environment exposed to dampness or to inclement weather.

NOTE: In case the lifter is not used less than a day in a 2-week period, the inspection should be performed before using the lifter.

• VACUUM PAD MAINTENANCE

- Friction coefficient
- The friction coefficient represents the ability of pad to engage the load during the lifting operation. The load capacity of most Aardwolf Lifter is based on a friction coefficient of 1 (except for Flat lifters)
- However, the ability of vacuum pad may be reduced by factors such as contamination, wear, aging and exposure to sunlight as well as the conditions of load surface.
- Moreover, the rubber of pad may be effected by other elements such as working environment, which cause reduce the life of pad.
- Therefore, it is strongly recommended that the pads should be replaced with a new, original one on a regularly 2-year basis to ensure the friction coefficient is not compromised.
- Pad inspection

To increase the life of rubber pad and to ensure the friction coefficient, the inspection of pad should follow the inspection schedule as mentioned above. Paying attention to the following elements that may effect on the pad:

- Contaminants on the pad surface or sealing edge: soils can prevent pads from adequately attaching or reduce the friction coefficient.
- Filter scrin helps prevent debris from plugging the vacuum hose and air filter. If missing, replace with a new, original one.
- Nicks, cuts or abrasion on sealing edge or wear, stiffness or glaze of pad can reduce the lifting capacity of lifter. Replace with a new, original one.

INSPECTIONS AND MAINTENANCE

- Pad cleaning

The cleaning of pad surface should be carried out on a regular basis to remove oil, dust or any contaminants with acceptable cleaning agents including soapy water and other mild cleansers.

Never use solvents, petroleum-based products including kerosene, gasoline and diesel fuel or any harsh chemical for cleaning.

Never use unauthorized rubber cleaners or conditioners, such as those intended for cleaning tires or vinyl surfaces, because those products can leave a hazardous film on vacuum pads which significantly reduces their lifting capacity. The use of any unauthorized cleaning agent is prohibited because it could damage the pad and/or create a hazard to the operator or others.

To prevent liquid from inflowing to the vacuum system during cleaning, cover the suction hole in the recess for the filter screen or make sure the pad faces downward.

Use a clean sponge or lint-free cloth to apply an authorized cleanser and wipe the pad face clean.

A toothbrush (or similar brush with bristles that do not harm rubber) may be used to remove contaminants clinging to sealing edges.

Wipe all residue from the pad face, and allow the pad to dry completely before using the lifter.

• **CHECKLIST OF MAINTENANCE ITEMS**

Inspect shackle/master link and suspension stud. Replace any worn or defective parts.

Check vacuum gauge(s) to make sure the dial has an uninterrupted travel. Make sure the capacity indication is clearly visible.

Check vacuum lifter on vacuum holding by lifting an absolutely clean, flat, nonporous, rigid test load and note amount of vacuum obtained at the start of the lift. If drop in vacuum is less than 10% within 4 min of initial vacuum, the lifter is in satisfactory condition for use. If vacuum drop is in excess of 10%, the lifter is unsafe and should be checked to find out the reason for vacuum leakage.

Tighten all clamps and lifting and replace damaged or worn parts. Check the air inlet valve on the top of cylinder cover to make sure that the valve disc is loose.

If any malfunctions are observed, check the trouble shooting procedure or contact your nearest Aardwolf service engineer or Aardwolf Industries LLC for service.

Dated records of inspection and maintenance should be kept by an appointed, responsible personnel.

A faulty or damaged vacuum lifting device shall be removed from service for repair. Return to service only after the defect has been corrected by an approved method using approved parts or materials as specified by the manufacturer.

INSPECTIONS AND MAINTENANCE

• REPLACING VACUUM PADS AND SEALING RINGS

A sealing ring is one of the most important parts of any vacuum lifter. The ability to maintain a tight vacuum bond with the load surface is critical to the operation of the lifter. However, the seals are susceptible to damage. Generally, a sealing ring fails for one of five reasons:

1. A cut, tear or excessive abrasion (due to wear or physical abuse).
2. Aging: Visible as excessive surface cracks or crazing due to ozone attack.
3. Hardening of the rubber due to ozone attack.
4. Compression set caused by improperly storing lifter.
5. Swelling of the rubber due to prolonged contact with certain hydrocarbons, i.e., oils or solvents.

Damaged seals should be promptly replaced. Defective seals should be disposed of.

Most vacuum seals have their part number molded on the outside lip. Please check the proper seal number before ordering replacements.

Declaration of conformity:

We declare that the lifter conforms with the following standards:

- The Machinery Directive 2006/42/EC
- Australian Standard 4991-2004.

Note:

It is the responsibility of the user to adapt to state or local laws. The end-user is responsible to use the equipment safely in a manner that it is designed for and within the rated capacity of the unit.

WARRANTY

After receiving the goods, it is strongly recommended to the buyer to check for sure, based on the spare part list and spare drawing attached with the goods, that the spare parts has not been damaged or lost during shipment. Any damages or losses must be officially claimed to Aardwolf Industries LLC's within 8 days since the date of goods receipts.

This lifter is granted a 12-month warranty based on Aardwolf Industries LLC's warranty policy from the date of purchase.

The warranty coverage is not applicable if:

- The lifter is handled incorrectly during maneuvering.
- The user fails to comply with the instructions in this booklet.
- The lifter's maximum permissible capacity is exceeded.
- The specifications for slab thickness are not followed.
- Damages are due to inadequate maintenance and inspections.
- Damage is due to improper storage.
- Repairs were performed by the user without our permission.
- Unofficial spare parts were used.

DISCLAIMER:

The Aardwolf Industries LLC's warranty does not cover the incorrect assembly and misuse of the lifter, the lack of maintenance and repair of the lifter as scheduled by the manufacturer, the operation carried out by non-competent or non-authorized operators or unofficial spare parts being used or installed.



WE ARE PROVIDING

SIMPLE, RELIABLE, COST SAVING
AND AWESOME IDEAS FOR YOUR BUSINESS



AARDWOLF PRODUCT VIDEO
www.youtube.com/user/AardwolfGroup



AARDWOLF SALES & SERVICE

AUSTRALIA

1/5 Stanton Road, Seven Hills NSW 2147

Tel: 02 9838 8427

www.aardwolfaustralia.com Email: enquiries@aardwolfaustralia.com

BULGARIA

Str.Usta Kolio Ficheto 33

Tel: +359 887 933 754

Email: adrian@toolrange.com

INDIA

Harama Road, Industrial Area, Madanganj, Kishangarh, District- Ajmer,
Rajasthan India 305801

Tel: +91 73000 68444

Web: www.aardwolf.co.in

Email: sales@aardwolf.co.in

GERMANY

Schulze-Delitzsch-Weg 2, 33175 Bad Lippspringe

Tel: 05252 8382830

Email: sales@aardwolf.com.de

USA

9401 Norwalk Blvd, Santa Fe Springs, CA 90760

Tel: (562) 553-6050

Web: www.aardwolfusa.com

Email: sales@aardwolfusa.com

VIETNAM

1B, An Phu, Thuan An City, Binh Duong Province, Vietnam

Tel: +84 931 707 793

Web: www.aardwolf.com.au

Email: info@aardwolf.com.au