

# GENERAL CATALOGUE



Get The Aardwolf Aadvantage

*Note: Image for illustrative purposes only. Actual product specifications may vary.*



Built on understanding the Stone industry's needs, Aardwolf Industries has been more than just a manufacturer for over three decades. We partner with stone fabricators and distributors worldwide.

Our commitment goes beyond producing over 350 high-quality tools and machines. We study the challenges, workflows, and priorities of the stone industry to create solutions that directly address what matters most: safety, efficiency, and profitability.

Stone fabricators face unique daily challenges—lifting heavy material safely, maximizing shop productivity, and ensuring every project meets the highest quality standards. Aardwolf understands these pain points because our roots are in the industry itself.

Mr. James Corbett, who owned and operated two large marble and granite processing companies in Australia, developed the first Patented Lifting Clamp for marble and granite in 1995. This innovation reduced workplace risks and sped up production, laying the foundation for Aardwolf Industries as a trusted problem-solver for stone professionals.

Aardwolf's heritage, combined with our continuous investment in research, development, and manufacturing, has made us a leader trusted by professionals who demand tools built by people who genuinely understand the stone industry.

To explore our full range of solutions, visit our website at [aardwolf.com.au](https://aardwolf.com.au) or contact us via [info@aardwolf.com.au](mailto:info@aardwolf.com.au) to learn how Aardwolf can help your business work safety, efficiency, and profitability.

# CONTENTS



## 01 AARDWOLF SLAB LIFTERS

04 - 07



## 02 SLAB LIFTERS

08 - 11



## 03 VACUUM LIFTERS

12 - 17



## 04 HAND CARRYING CLAMPS & OTHERS

18 - 21



## 05 TROLLEYS & HAND TRUCKS

22 - 24



## 06 JIB CRANES

25 - 27

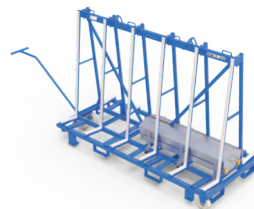

## 07 A-FRAMES

28 - 33



## 08 SLAB & BUNDLE RACKS

34 - 37



## 09 FORKLIFT EQUIPMENT

38 - 41



## 10 WORKBENCHES & STANDS

42 - 45

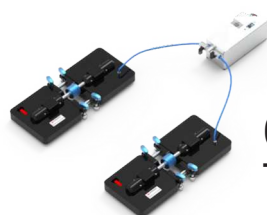

## 11 COUNTERTOP TOOLS

46 - 47



## 12 WORKSHOP EQUIPMENT

48 - 51

# 01

# AARDWOLF SLAB LIFTER FAMILY



## WIDE JAW SERIES

- ★ Designed for handling thin and fragile material (glass, porcelain etc).
- ★ Useful in stone yards and construction sites.



AL20AWJ



AL30AWJ



AL40AWJ

PRODUCT CODE	Grip Range	Working Load Limit	Net Weight
AL20AWJ	0 - 20 mm   0 - 3/4"	1200 kg/ 2646 lb	21 kg/ 47.2 lb
AL30AWJ	0 - 30 mm   0 - 1 1/8"		24.4 kg/ 53.8 lb
AL40AWJ	3 - 40 mm   1/8 - 1 5/8"		24.5 kg / 54 lb

# AUTO LOCK SERIES

- ★ Features automatic locking/unlocking for rapid operation.
- ★ Mechanism automatically locks and unlocks for safer and faster handling.



PRODUCT CODE	Grip Range	Working Load Limit	Net Weight
AL30A	0 - 30 mm   0 - 1 1/8"	1200 kg/ 2646 lb	18.1 kg/ 40 lb
AL40A	3 - 40 mm   1/8" - 1 5/8"		19.3 kg/ 42.5 lb
AL50A	10 - 50 mm   3/8 - 2"		19.4 kg/ 42.8 lb
AL60A	15 - 60 mm   5/8 - 2 3/8"		25 kg/ 55 lb
AL75A	30 - 75 mm   1 1/8 - 3"		25 kg/ 55 lb



Original Slab Lifters from Aardwolf, conceived and patented by the company's founder, James Edmund Corbett.



**SCAN HERE**  
To visit the Category

# MANUAL UNLOCK SERIES

- ★ Offers manual control for precision and secure lifting.
- ★ Manual control of the locking mechanism.
- ★ Preferred where operator control and stability are prioritized.



AL30

AL40

AL50

AL60

AL75

PRODUCT CODE	Grip Range	Working Load Limit	Net Weight
AL30	0 - 30 mm   0 - 1 1/8"	1200 kg/ 2646 lb	17.8 kg/ 39.2 lb
AL40	3 - 40 mm   1/8" - 1 5/8"		19.3 kg/ 42.5 lb
AL50	10 - 50 mm   3/8 - 2"		19 kg/ 42 lb
AL60	15 - 60 mm   5/8 - 2 3/8"		25 kg/ 55 lb
AL75	30 - 75 mm   1 1/8 - 3"		25 kg/ 55 lb



## AUTO LOCK

The Locking Pin automatically locks alternatively, making it easy to raise and lower the slab.



## MANUAL UNLOCK

Pull down the Locking Latch to release the Locking Pin for lifting slab materials.



## SMART ROLLERS

Adjusts the Lifter's position along the slab easily.

# AARDWOLF TWISTER

## KEY FEATURES

- ★ One-man operation for safe slab handling without ground personnel
- ★ 360° dual-direction rotation via remote control
- ★ Compact & lightweight design for tight spaces
- ★ Adjustable rotation speed for precise positioning
- ★ 24V battery with 8-hour runtime for energy-efficient performance
- ★ Impact-resistant construction for harsh conditions
- ★ Operation indicator light for clear status visibility



### FLEXIBLE CONNECTION

Works with forklifts or truck cranes and Aardwolf Slab Lifters.



MSS03



### 360-DEGREE ROTATION

360-degree rotation capability for precise placement, operated by remote control.

## PRODUCT CODE

MSS03

## Working Load Limit

1200 kg/ 2646 lb

## Net Weight

23 kg/ 51 lb

# AARDWOLF GLASS LIFTERS



## KEY FEATURES

- ★ Automated locking mechanism for secure grip and safe release of glass sheets
- ★ Protective rubber-coated surfaces for scratch-free handling and edge protection



AL30AWJH



AGL SERIES

PRODUCT CODE	Grip Range	Working Load Limit	Net Weight
AGL22	2 - 22 mm   1/8 - 7/8"	750 kg/ 1653 lb	23.6 kg / 52 lb
AGL32	2 - 32 mm   1/8 - 1 1/4"	750 kg/ 1653 lb	28 kg/ 62 lb
AL30AWJH	0 - 30 mm   0 - 1 1/8"	1200 kg/ 2646 lb	25.2 kg / 55.6 lb

# SLAB LIFTERS

# 02



**Aardwolf Scissor Clamp Lifters** are engineered for safe, vertical lifting of heavy materials like stone, concrete, and retaining wall sleepers. They are widely used in construction, fabrication, and landscaping, with common features across models.

## KEY FEATURES

- ★ **Gravity-controlled auto-locking systems:** Engages during lifting, releases when set down — no manual intervention needed.
- ★ **Replaceable high-friction rubber pads:** Ensure grip and protect material surfaces. Powder-coated safety yellow finish
- ★ **Heavy-duty steel construction:** Powder-coated yellow for visibility and rust resistance.
- ★ **Crane hook:** Central position for stability and safe crane/ forklift attachment.

**Optional Extra:** Short Chain and Shackle

## OPTIONAL EXTRA: SHORT CHAIN AND SHACKLE

Enhances flexibility on construction sites and reduces strain on the locking pin during operation.



# AARDWOLF SCISSOR CLAMP LIFTERS



**ASL105**

Compact, precise centering, ideal for retaining wall sleepers



**ASL125**

Slightly larger grip range than ASL105.



**ASL200**

Higher capacity, extended grip for



**ASL300**

Great for varied material sizes and heavy-duty lifting



**ASL450**

Largest grip range, heaviest-duty usage



**SCAN HERE**  
To visit the Category



CODE	Grip Range	Working Load Limit	Net Weight
ASL105	0 - 105 mm   0 - 4"	750 kg/ 1653 lb	24 kg/ 53 lb
ASL125	0 - 125 mm   0 - 5"	750 kg/ 1653 lb	29 kg/ 64 lb
ASL200	50 - 200 mm   2 - 8"	1500 kg/ 3307 lb	47 kg/ 104 lb
ASL300	150 - 300 mm   6 - 12"	1500 kg/ 3307 lb	48 kg/ 106 lb
ASL450	300 - 450 mm   12 - 18"	2000 kg/ 4408 lb	85 kg/ 187 lb

# HORIZONTAL STONE LIFTING CLAMPS



## KEY FEATURES

- ★ Auto lock & release for hands-free operation
- ★ Adjustable grip range for different block sizes
- ★ High load capacity for heavy slabs and blocks
- ★ Durable pads for secure grip and surface protection



**AHLC-730**



**AHLC-1050**



**AHLC-1370**

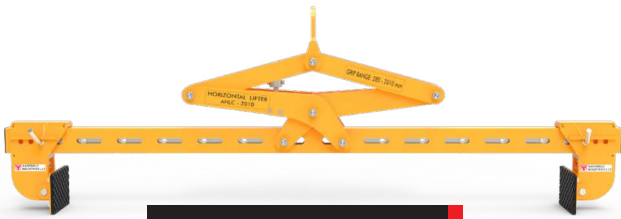

**AHLC-2010**



**AHLC-2010-4T**

**BODY STOPPER**

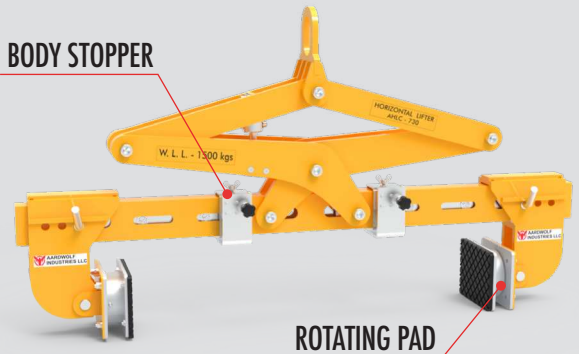

**ROTATING PAD**

## OPTIONAL EXTRA: ROTATING PADS & BODY STOPPERS

Enhances stability and precision when lifting and lowering large stone slabs. Optional accessories available upon request.

PRODUCT CODE	Grip Range	Working Load Limit	Net Weight
AHLC-730	280 - 730 mm   11" - 28 3/4"	1500 kg/ 3307 lb	112 kg/ 247 lb
AHLC-1050	280 - 1050 mm   11" - 41 3/8"		121 kg/ 267 lb
AHLC-1370	280 - 1370 mm   11" - 54"		124 kg/ 273 lb
AHLC-2010	280 - 2010 mm   11" - 79 1/8"		137 kg/ 302 lb
AHLC-2010-4T	300 - 2010 mm   11 3/4" - 79 1/8"		4000 kg/ 8818 lb

# VERSA BLOCK CLAMPS, MONUMENT CLAMPS & BARRIER LIFTERS

## VERSA BLOCK CLAMPS ▶ KEY FEATURES

- ★ Auto grip & release for easy handling
- ★ Adjustable jaw width for various sizes
- ★ Reversible sliding pads for secure grip on various shapes



AVBC-600



AVBC-1100

PRODUCT CODE	Grip Range	Working Load Limit	Net Weight
AVBC-600	100 - 600 mm   4" - 23 5/8"	1200 kg/ 2646 lb	50 kg/ 110 lb
AVBC-1100	150 - 1100 mm   5 7/8" - 43 1/4"	3000 kg/ 6614 lb	161 kg/ 355 lb

## MONUMENT CLAMPS ▶ KEY FEATURES

- ★ Gravity-controlled auto clamp for hands-free operation
- ★ Adjustable jaw & center of gravity for easy positioning
- ★ Vulcanized rubber pads for secure, non-marking grip

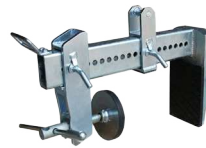

GPM1000



GPM1000A



GPM1500A

GPM SERIES

PRODUCT CODE	Grip Range	Working Load Limit	Net Weight
GPM1000	0 - 407 mm   0 - 16"	1000 kg/ 2204 lb	33 kg/ 73 lb
GPM1000A	20 - 300 mm   3/4" - 11 3/4"	1000 kg/ 2204 lb	33 kg/ 73 lb
GPM1500A	20 - 300 mm   3/4" - 11 3/4"	1500 kg/ 3307 lb	52 kg/ 115 lb

## BARRIER LIFTERS ▶ KEY FEATURES

- ★ Automatic locking mechanism for safe, hands-free lifting
- ★ Vulcanized rubber pads protect surfaces from damage
- ★ Protective rubber-lined bar prevents chipping on edge



ABL SERIES



ADBL-2000

PRODUCT CODE	Grip Range	Working Load Limit	Net Weight
ABL255-2000	100 - 255 mm   4" - 10"	2000 kg/ 4408 lb	84 kg/ 185 lb
ABL255-3000	100 - 255 mm   4" - 10"	3000 kg/ 6614 lb	146 kg/ 322 lb
ABL360-5000	100 - 360 mm   4" - 14 1/8"	5000 kg/ 11023 lb	426 kg/ 939 lb
ADBL-2000	155 - 250 mm   6 1/8" - 9 7/8"	2000 kg/ 4408 lb	264 kg/ 582 lb



Get The Aardwolf Advantage

Custom solutions by Aardwolf

**YOUR IDEA, OUR  
SOLUTION CUSTOMIZED  
TO FIT YOUR JOB.**



AARDWOLF PRODUCT VIDEO:  
[www.youtube.com/@Aardwolf.English](http://www.youtube.com/@Aardwolf.English)

 [info@aardwolf.com.au](mailto:info@aardwolf.com.au)

 [www.aardwolf.com.au](http://www.aardwolf.com.au)



# 03

# VACUUM LIFTERS



This pneumatic vacuum lifter provides safe, efficient handling of smooth and rough marble or granite slabs. With 90° tilting, strong vacuum grip, and durable construction, it's ideal for workshops, construction sites, and manufacturing facilities.



AVLP4-P-1000



**SCAN HERE**  
To visit the Category

PRODUCT CODE	Pad Size	Working Load Limit (Vertical - Horizontal)	Net Weight
AVLP4-P-1000	500 x 300 mm 19 3/4" x 11 3/4"	500 - 1000 kg 1102 - 2204 lb	104 kg/ 229 lb

# VACUUM LIFTER PRO AVLP SERIES

## KEY FEATURES

- ★ Pneumatic tilting 0–90° for easy slab positioning
- ★ Dual modes with audio alarm for low vacuum & Energy saver to auto-start/stop pump
- ★ Vacuum tank safety maintains suction if air supply is lost
- ★ Rechargeable alarm system alerts low vacuum pressure for safe operation
- ★ Slide valve ON/OFF for quick, reliable material release
- ★ Durable aluminum handle with adjustable extensions



**AVLP1-250P**



**AVLP2-500P**



**AVLP3-600P**

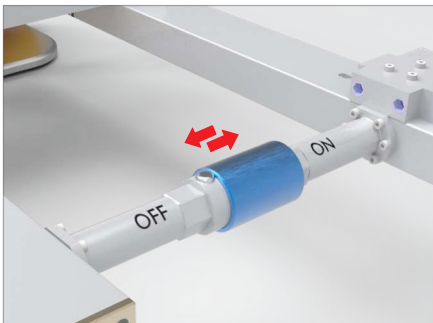

### SLIDE VALVE MECHANISM

Easy ON/OFF slide valve for quick material attachment and release.

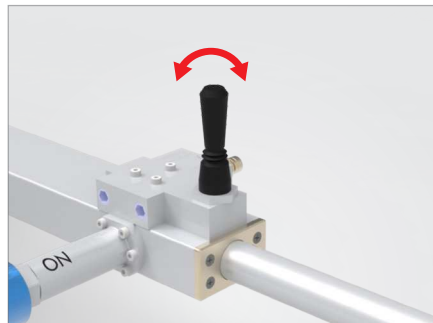

### PNEUMATIC TILTING

Enables vertical-horizontal movement from 0° to 90° for versatile handling.



### SAFETY SYSTEM

Provides real-time monitoring and alerts for maximum safety

PRODUCT CODE	Pad Size	Working Load Limit	Net Weight
AVLP1-250P	500 x 300 mm 19 3/4" x 11 3/4"	125 - 250 kg 276 - 551 lb	48 kg/ 106 lb
AVLP2-500P	500 x 300 mm 19 3/4" x 11 3/4"	250 - 500 kg 551 - 1102 lb	70 kg/ 154 lb
AVLP3-600P	500 x 300 mm 19 3/4" x 11 3/4" (2 outer pads) 400 x 200 mm 15 3/4" x 7 7/8" (1 central pad)	300 - 600 kg 661 - 1312 lb	72 kg/ 159 lb

# VACUUM LIFTERS

## VACUUM BLOCK LIFTERS

### ► KEY FEATURES

- ★ Automatic vacuum system for safe, energy-efficient operation
- ★ Visual and audio alerts for real-time vacuum monitoring
- ★ Quick-change pads minimize downtime



AVBL-380

NEW 2025



AVBL-1000

PRODUCT CODE	Pad Size	Working Load Limit	Net Weight
AVBL-380	420 x 220 mm   16 1/2" x 8 5/8"	220 kg/ 485 lb	53 kg/ 116.8 lb
	500 x 125 mm   19 3/4" x 4 7/8"	126 kg/ 278 lb	
	500 x 150 mm   19 3/4" x 5 7/8"	164 kg/ 362 lb	
	500 x 300 mm   19 3/4" x 11 3/4"	380 kg/ 838 lb	
AVBL-1000	800 x 500 mm   31 1/2" x 19 3/4"	1000kg/ 2204 lb	67 kg/ 147.7 lb

## SWIFTLIFT



NEW 2025

ASVL-380



## VACUUM BLOCK LIFTER WITH HANDLE ► KEY FEATURES

- ★ Automatic vacuum system with real-time visual and audio feedback
- ★ Dual controls handle-mounted for precision or body-mounted for wider access
- ★ Ergonomic handle for safe and easy manual handling



NEW 2025

AVBLH380

PRODUCT CODE	Pad Size	Working Load Limit	Net Weight
ASVL-380	420 x 220 mm   16 1/2" x 8 5/8"	220 kg/ 485 lb	15 kg/ 33 lb
	500 x 300 mm   19 3/4" x 11 3/4"	380 kg/ 838 lb	
AVBLH380	500 x 300 mm   19 3/4" x 11 3/4"	380 kg/ 838 lb	33 kg/ 72 lb

# VACUUM LIFTERS

## VACUUM PAVER LIFTER & PAVING STONE LIFTER ► KEY FEATURES

- ★ Quality construction.
- ★ Various vacuum pads.



CODE	Pad Size	Working Load Limit
AVPL40	120 x 220 mm   4 3/4" x 8 5/8"	40 kg/ 88 lb
	80 x 120 mm   3 1/8" x 4 3/4"	12 kg/ 26 lb
	Ø150 mm   5 7/8"	40 kg/ 88 lb
APSL	276 x 176 mm   10 7/8" x 6 7/8"	110 kg/ 243 lb
	186 x 86 mm   7 3/8" x 3 3/8"	28 kg/ 62 lb

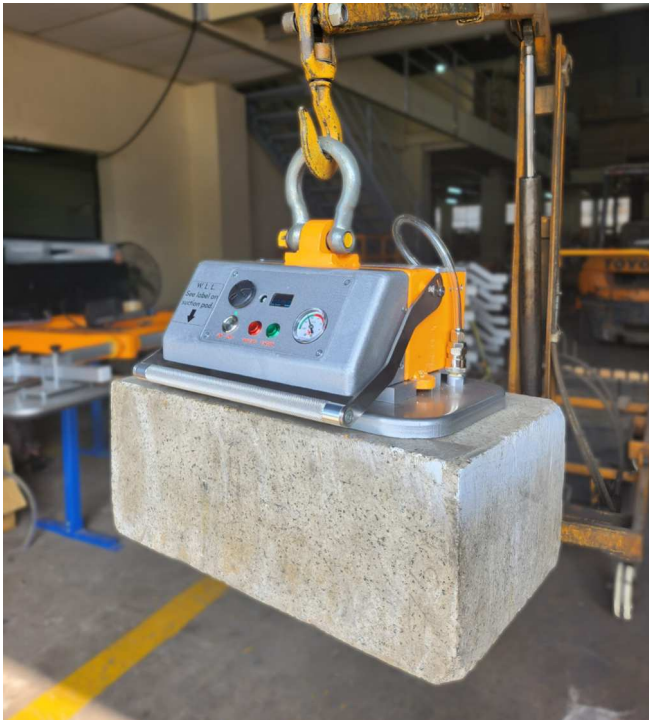

## HANDY VACUUM LIFTER

### KEY FEATURES

- ★ Powered by a 12V clip-in battery.
- ★ Fast assembly for switching pads.
- ★ Visual monitor and alarm system.



ABHVL-380

PRODUCT CODE	Pad Size	Working Load Limit	Net Weight
ABHVL-380	500 x 300 mm   19 3/4" x 11 3/4" <i>(Original pad size)</i>	380 kg/ 838 lb	18 kg/ 39.6 lb
	500 x 125 mm   19 3/4" x 4 7/8"	126 kg/ 278 lb	
	500 x 150 mm   19 3/4" x 5 7/8"	164 kg/ 362 lb	
	420 x 220 mm   16 1/2" x 8 5/8"	220 kg/ 485 lb	

# VACUUM LIFTERS

## VACUUM BLOCK LIFTERS ▶ KEY FEATURES

- ★ The metal structure is tilted from 0 to 90-degree manually.
- ★ Compressed air-operated vacuum pump at a pressure of 5-6 Bars.
- ★ Slider valve with ON/OFF position.



AVLM2

PRODUCT CODE	Pad Size	Working Load Limit	Net Weight
AVLM2	500 x 300 mm   19 3/4" x 11 3/4"	500 kg/ 1102 lb	48 kg/ 106 lb

## MONO MECHANICAL VACUUM LIFTERS

### KEY FEATURES

- ★ Self-powered and self-cycling.
- ★ Extremely safe, the load cannot be released until it is set down on the surface.
- ★ Capable of 100% duty cycle, 24 hours/day operation.



AMMVL SERIES

**AMMVL150**

Pad Diameter	W.L.L	Net Weight
200 mm 7 7/8"	150 kg 331 lb	12 kg 26 lb

PRODUCT CODE	Pad Diameter	Working Load Limit	Net Weight
AMMVL270	300 mm   11 3/4"	270 kg/ 595 lb	22 kg/ 49 lb
AMMVL650	450 mm   17 3/4"	650 kg/ 1433 lb	36 kg/ 79 lb
AMMVL1000	530 mm   20 7/8"	1000 kg/ 2204 lb	55 kg/ 121 lb

# VACUUM LIFTERS



PRODUCT CODE	Pad Size	Working Load Limit	Length-width of sheet material
FMVLA04-2T	508x808 mm   20"x32"	2000 kg/ 4408 lb	3000x3000 mm   118"x118"

## FORK MOUNTED VACUUM LIFTING ATTACHMENT ► KEY FEATURES

- ★ Designed to lift and lower sheet materials and large panels such as glass, stone, metal, concrete, plastics, timber, and laminates.
- ★ Works with forklift and remote control.

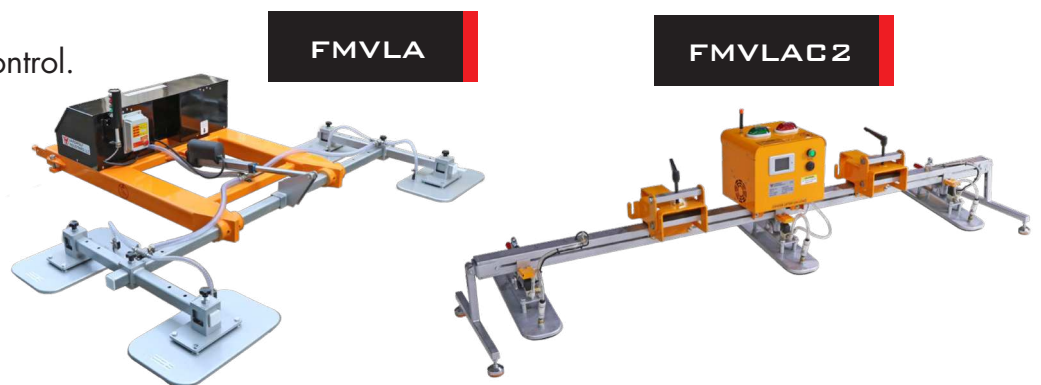

PRODUCT CODE	FMVLA	FMVLAC2
Pad Size	500 x 300 mm   19 3/4" x 11 3/4"	500 x 133 mm   19 3/4" x 5 1/4"
Working Load Limit	Vertical: 760 kg/ 1676 lb Horizontal: 1000 kg/ 2204 lb	150 kg/ 331 lb
Net Weight	275 kg/ 606 lb	65 kg/ 143 lb

# VACUUM LIFTERS



## VACUUM LIFTER WITH PETROL FUELED ENGINE

### ▶ KEY FEATURES

- ★ Compact and robust structure.
- ★ Integrated vacuum gauge for controlling the vacuum leak
- ★ Lifting eye for easy attachment to a mobile crane
- ★ Slide valve with ON/OFF position for gripping and releasing of material.



PRODUCT CODE	Pad Sizes	Working load limit
APVL-1000	800 x 500 mm   31 1/2" – 19 3/4"	1000 kg/ 2204 lb

## VACUUM LIFTER PARKING STATIONS



Can be used in combination with vacuum lifter models AVLP1 / AVLP4. Parking station mounted on wheels. Ideal for moving the vacuum lifter to a safe storage area when not in use. It allows the vacuum lifter to be parked without the vacuum pads coming into contact with the floor, workbench or other surfaces that could damage the vacuum pads.

PRODUCT CODE	Packaging dimensions
PSAVLP1	840x400x200 mm   33 1/8"x15 3/4"x7 7/8"
PSAVLP2	860x390x210 mm   33 7/8"x15 3/8"x8 1/4"

# DC POWERED VACUUM GLASS LIFTERS



## DC POWERED VACUUM GLASS LIFTER

### ► KEY FEATURES

- ★ 360-degree manual rotation with 45-degree increments.
- ★ 90-degree manual tilting.
- ★ Integrated instrumentation for monitoring vacuum levels and energy supply.
- ★ Visual and audible warning system.
- ★ High-capacity 12-volt battery power supply.
- ★ Extension arms for handling large sheets.

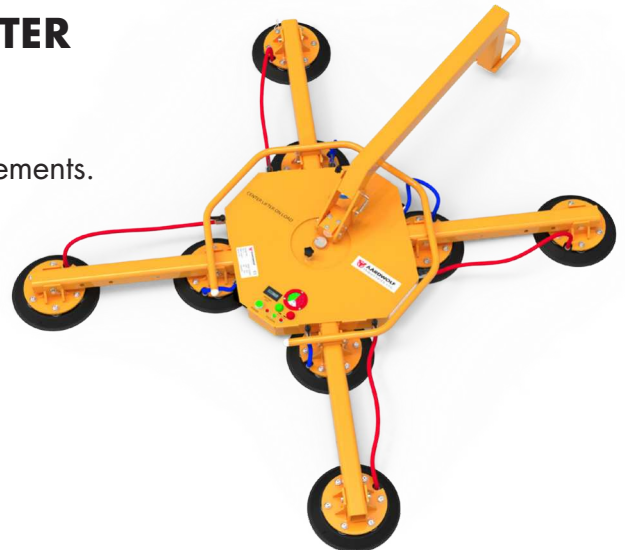

PRODUCT CODE	Number Of Pad	Pad Diameter	Working Load Limit	Net Weight
ARGL-500	4	300 mm   11 3/4"	Vertical: 400 kg/ 882 lb	69 kg/ 152 lb
ARGL-500Ds	8	300 mm   11 3/4"	Horizontal: 500 kg/ 1102 lb	81 kg/ 179 lb

# VACUUM GLASS LIFTERS



**AVGLP2-200**



**AVGLP2-AR**



**AVGLP4-400**



**AVGLP8-800**



**AVGLP4-MR-250**



**AVGLP6-500**



**AVGLM2-200**



**AVGLP4-400L**



**AVLB4**

PRODUCT CODE	Number Of Pad	Pad Diameter	Working Load Limit	Net Weight
AVGLP2-200	2	300 mm	200 kg/ 441 lb	64 kg/141 lb
AVGLP2-AR	2		200 kg/ 441 lb	60 kg/132 lb
AVGLP4-400	4		200 - 400 kg/ 441 - 882 lb	79 kg/174 lb
AVGLP8-800	8		400 - 800 kg/ 882 - 1764 lb	108 kg/238 lb
AVGLP4-MR-250	4	11 3/4"	250 kg/ 551 lb	81 kg/179 lb
AVGLP6-500	6		500 kg/ 1102 lb	173 kg/381lb
AVGLM2-200	2		200 kg/ 441 lb	42 kg/93 lb
AVGLP4-400L	4	150 mm   6 1/4"	200 - 400 kg/ 441 - 882 lb	82 kg/181 lb
AVLB4	4		160 kg/ 353 lb	28 kg/ 62 lb

# ELECTRIC VACUUM LIFTERS



**AEPVGL-MR**



**AEVGLP8-800**



**AEVGLP4-500**



**AERV-180**



**AEVLP4-500**



**AEVLP8-1000**



**AEVLP8-2000**



**ARV-180**

PRODUCT CODE	Number Of Pad	Pad Diameter	Working Load Limit	Net Weight
AEPVGL-MR	8	300 mm	500 kg/ 1102 lb	204 kg/450 lb
AEVGLP8-800	8	-	400 - 800 kg/ 882 - 1764 lb	203 kg/448 lb
AEVGLP4-500	4	11 3/4"	400 - 500 kg/ 882 - 1102 lb	145 kg/320 lb
AERV-180	4	200 mm   7 7/8"	160 kg/ 353 lb	60 kg/132 lb
AEVLP4-500	4	300 mm	500 kg/ 1102 lb	192 kg/423lb
AEVLP8-1000	8	11 3/4"	1000 kg/ 2204 lb	-
AEVLP8-2000	8	350 mm   13 3/4"	2000 kg/ 4408 lb	370 kg/816 lb
ARV-180	4	200 mm   7 7/8"	160 kg/ 353 lb	69 kg/152 lb

# 04

# VACUUM CUPS & HAND CARRYING CLAMPS



HVC

## HAND VACUUM CUPS ► KEY FEATURES

- ★ **Superior Safety:** Securely grips glass surfaces, reducing manual handling risks and preventing workplace injuries.
- ★ **Enhanced Efficiency:** Allows quicker, more precise handling and positioning of glass materials, improving overall productivity.
- ★ **Cost-Effectiveness:** Minimizes glass breakage and reduces downtime, resulting in significant operational cost savings.



**SCAN HERE**  
To visit the Category

PRODUCT CODE	Grip Range	Working Load Limit	Net Weight
HVC	220 mm   8 5/8"	100 kg/ 220 lb	1.3 kg/ 2.9 lb

## HAND CARRYING CLAMPS & OTHERS

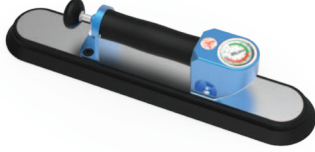

OHVC

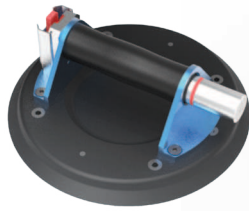

HVCO1



HVC05



HVC06

PRODUCT CODE	Cup Diameter	Working Load Limit	Net Weight
OHVC	380 x 80 mm   15" x 3 1/8"	100 kg/ 220 lb	1.3 kg/ 2.9 lb
HVCO1	220 mm   8 5/8"	100 kg/ 220 lb	1.3 kg/ 2.9 lb
HVC05	122 mm   4 3/4"	50 - 100 kg/ 110 - 220 lb	0.8 kg/ 1.8 lb
HVC06	122 mm   4 3/4"	75 - 150 kg/ 165 - 331 lb	1 kg/ 2.2 lb

## STONE CARRYING HAND CLAMPS ► KEY FEATURES

- ★ **Construction:** Efficiently manage heavy stone slabs, optimizing workflow on construction sites.
- ★ **Stone Processing:** Enhance productivity and safety during handling and processing of stone materials.
- ★ **Landscaping:** Simplify installation and transportation of stones, improving project timelines and reducing labor costs.



ASKC200



SCC04



SCC02 - SCC03 - SCC05 - SCC06

PRODUCT CODE	Grip Range	Working Load Limit	Net Weight
SCC02	0 - 52 mm   0 - 2"	150 kg/ 331 lb (pair)	2 kg/ 4 lb
SCC03	0 - 50 mm   0 - 2"	200 kg/ 441 lb (pair)	7.4 kg/ 16.3 lb
SCC04	100 - 500 mm   4" - 19 3/4"	200 kg/ 441 lb	16.9 kg/ 37.3 lb
SCC05	50 - 100 mm   2" - 4"	200 kg/ 441 lb (pair)	8.3 kg/ 18 lb
SCC06	0 - 50 mm   0 - 2"	200 kg/ 441 lb (pair)	7 kg/ 15.4 lb
ASKC200	0 - 260 mm   0 - 10 1/4"	200 kg/ 441 lb	23 kg/ 51 lb

# LOAD-HANDLING-ATTACHMENTS - CARGO SLINGS

## SPREADER BEAMS

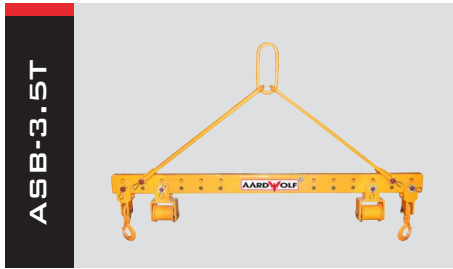

### ► KEY FEATURES

- ★ Adjustable lifting points.
- ★ Handle both wide and unbalanced loads.
- ★ Includes swivel hooks and rollers.

PRODUCT CODE	Working Load Limit	Net Weight
ASB-2.5T	2500 kg/ 5511 lb	46 kg/ 101 lb
ASB-3.5T	3500 kg/ 7716 lb	73 kg/ 161 lb
ASB-5T	5000 kg/ 11023 lb	105 kg/ 231 lb

## PALLET CRANE FORK



APCF

Working Load Limit  
2500 kg/ 5511 lb

### ► KEY FEATURES

- ★ High-strength welded steel construction for maximum strength and durability.
- ★ Moves palletized items efficiently and safely into different production environments.

## CARGO LASHINGS SLINGS ► KEY FEATURES

- ★ **Logistics and Transportation:** Secure cargo across various transport methods, ensuring efficient and safe deliveries.
- ★ **Construction:** Reliable stabilization and secure transport of construction materials and equipment.



# SLAB BUNDLE HANDLERS, BRICK GRABS LIFTER, ROCK LIFTER



## SLAB BUNDLE HANDLERS ► KEY FEATURES

- ★ For lifting glass bundles, marble and granite slabs from closed-top containers.
- ★ Increase efficiency and worker safety.

PRODUCT CODE	Working Load Limit	Net Weight
GBH01	2500 kg/ 5511 lb	2030 kg/ 4475 lb
SBH01	3000 kg/ 6614 lb	2000 kg/ 4409 lb
SBH02	5000 kg/ 11023 lb	3200 kg/ 7055 lb

## BRICK GRAB LIFTER ► KEY FEATURES

- ★ **Construction Sites:** Efficient and safe handling of bricks during building and renovation projects.
- ★ **Masonry Work:** Simplified transport and precise placement of bricks, enhancing quality and speed.
- ★ **Landscaping Projects:** Streamlined management of brick materials for landscape features and paving.

PRODUCT CODE	Grip range	Working load limit
ABGL-1800	800 - 1100 mm 31 1/2" - 43 1/4"	1800 kg/ 3968 lb
Pad length: 1200 mm - 47 1/4" - Internal height: 1100 mm - 43 1/4"		



## AARDWOLF ROCK LIFTERS ► KEY FEATURES

- ★ **Increased Efficiency:** Automating stone lifting operations dramatically reduces manual effort, speeding up project timelines and boosting productivity.
- ★ **Enhanced Safety:** By eliminating manual handling, the Aardwolf Rock Lifter significantly reduces the risk of injuries, creating a safer work environment.

CODE	Grip range	Working load limit
ASG	350-1200 mm 13 3/4"- 47 1/4"	2000kg/4408 lb
ARL800	350-800 mm 13 3/4"- 1 1/4"	750kg/1653 lb
ARL1200	600-1200 mm 23 5/8"- 47 1/4"	1500kg/3307 lb

## PIPE LIFTERS

### CONCRETE PIPE LIFTERS ► KEY FEATURES

- ★ Auto locks and unlocks a load.
- ★ Vulcanized rubber pads.
- ★ Durable powder-coated finish.



PRODUCT CODE	Grip Range	Working Load Limit	Net Weight
ACPL750	400 - 500 mm   15 3/4" - 19 3/4"	750 kg/ 1653 lb	150 kg/ 331 lb
ACPL1500	500 - 750 mm   19 3/4" - 29 1/2"	1500 kg/ 3307 lb	226 kg/ 498 lb
ACPL2500	750 - 1000 mm   29 1/2" - 39 3/8"	2500 kg/ 5511 lb	564 kg/ 1243 lb

### ROUND BAR LIFTERS ► KEY FEATURES

- ★ Handling long steel pipes and tubes, especially for steel pipe assembly system.
- ★ Made from durable steel material.
- ★ Sturdy and safe construction.



RBL200

RBL305

PRODUCT CODE	Grip Range	Working Load Limit	Net Weight
RBL200	100 - 200 mm   4" - 7 7/8"	150 kg/ 331 lb	7 kg/ 15 lb
RBL305	200 - 305 mm   7 7/8" - 12"	320 kg/ 706 lb	26 kg/ 57 lb

### PIPE HANDLING ATTACHMENT ► KEY FEATURES

- ★ Auto locks and unlocks a load.
- ★ Durable powder-coated finish.



PRODUCT CODE	Grip Range	Pipe length	Working Load Limit
PHA4000	300 - 1200 mm   11 3/4" - 47 1/4"	2500 mm   98 3/8"	4000 kg/ 8818 lb

# VACUUM TUBE LIFTERS

## VACUUM TUBE LIFTERS ► KEY FEATURES

- ★ **High-Performance Vacuum Pump:** Ensures high-speed, energy-efficient performance to enhance operational efficiency.
- ★ **Versatile Operation Modes:** Offers manual and remote operation modes for effortless adaptation to different needs.
- ★ **Comfortable Head:** Features an ergonomic Control Hand and top gate valve for precise control during lifting and releasing operations.



AVTL 1

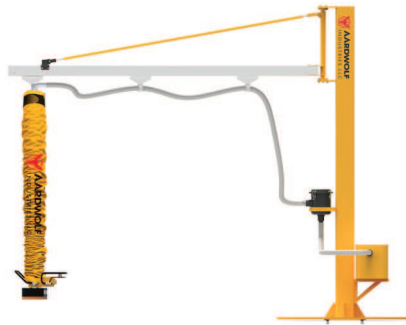

AVTL 2



AVTL-CF3

PRODUCT CODE	Crane Capacity	Height Of The Crane	Arm Length
AVTL 1	100 kg/ 220 lb	3150 mm   124"	3050 mm   120"
AVTL 2	100 kg/ 220 lb	3150 mm   124"	3260 mm   128 3/8"
AVTL-CF3	100 kg/ 220 lb	2552 mm   100 1/2"	2431 mm   95 3/4"

## TURF PAVING ATTACHMENT

The Turf Paving Block Lifter from Aardwolf is an innovative tool designed to significantly enhance paving efficiency, with the capability to install four blocks at once. This feature is particularly beneficial for large-scale landscaping projects, where time and precision are of the essence.



### BILLET LIFTER

BL59

TPBL-600

PRODUCT CODE	Grip Range	Working Load Limit
TPBL-600	100 - 600 mm 4" - 23 5/8"	1200 kg/ 2646 lb
BL59	5 - 60 mm 1/4" - 2 3/8"	200 kg/ 4409 lb

## BOX LIFTING CLAMP



### BOX LIFTING CLAMP ► KEY FEATURES

- ★ **Gravity-Controlled Locking Latch:** Automatically grips and releases materials for seamless handling.
- ★ **Replaceable Pads:** Easily switch pads to accommodate various materials and load sizes.
- ★ **Flexible Design:** Removable arms allow for handling loads ranging from large cartons to smaller items.

PRODUCT CODE	Grip range	Working load limit
CBL-680	65 - 680 mm 2 1/2" - 26 3/4"	100 kg/ 220 lb

### BAG GRAB LIFTER ► KEY FEATURES

- ★ **Enhanced Productivity:** Automated and efficient bag handling significantly increases productivity by speeding up lifting and transporting processes.
- ★ **Improved Safety:** By reducing manual lifting, the Aardwolf Bag Grab Lifter ensures a safer working environment, decreasing the incidence of workplace injuries.

PRODUCT CODE	Grip range	Working load limit
BGL-600	400 - 600 mm 15 3/4" - 23 5/8"	100 kg/ 220 lb



### DRUM CLAMP ► KEY FEATURES

- ★ **Chemical Industry:** Safe handling of hazardous substances in drums.
- ★ **Pharmaceuticals:** Precise lifting and transporting of delicate or heavy drums.
- ★ **Manufacturing:** Effective management of raw materials and finished goods stored in drums.
- ★ **Logistics and Warehousing:** Efficiently moving drums to streamline inventory and warehouse management.

PRODUCT CODE	Grip range	Working load limit
ADC-572	572 mm   22 1/2"	100 kg/ 220 lb

# TROLLEYS

# 05



The automatic clamping feature allows the trolley to move and transport heavy slab materials in a flexible and easy manner. Pneumatic wheels with a high grip meet the demand for transport on every terrain, from even to rough.



SL100



**SCAN HERE**  
To visit the Category

PRODUCT CODE	Grip Range	Working Load Limit	Net Weight
SL155	0 - 100 mm   0 - 4"	400 kg/ 882 lb	28 kg/ 62 lb

# SELF-LOCKING TROLLEYS

## KEY FEATURES

- ★ Grips material automatically and securely.
- ★ Clamping supports and base are rubber-padded.
- ★ Quickly moves the materials.



TRANSPORTING GLASS SLAB



TRANSPORTING STONE SLAB



SL60



SL85



SL155

PRODUCT CODE	Grip Range	Rubber Wheel	Support plate
SL60	0 - 60 mm   0 - 2 3/8"	265 mm   10 3/8"	500 mm   19 3/4"
SL85	0 - 85 mm   0 - 3 3/8"	400 mm   15 3/4"	500 mm   19 3/4"
SL155	0 - 155 mm   0 - 6 1/8"	400 mm   15 3/4"	500 mm   19 3/4"

# TROLLEYS & HAND TRUCKS

## TROLLEYS ▶ KEY FEATURES

- ★ Ideal for moving slab, door frames and other wide materials, includes Slab Trolley, Load Trolley, Quad Trolley, Broad Trolley.



TROLLEY SERIES

## MASTER TROLLEY ▶ KEY FEATURES

- ★ Designed to facilitate the transportation of panel slabs or countertops.

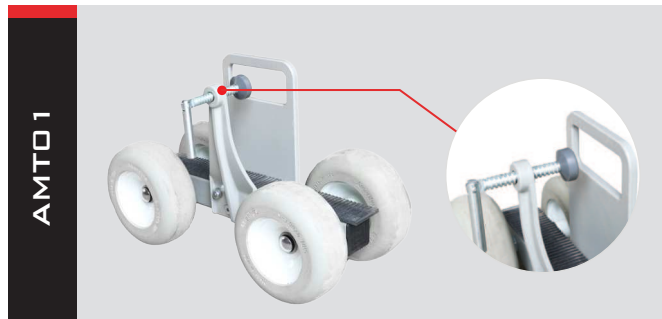

AMTO 1

CODE	Rubber Wheel	Working Load Limit	Support Plate
ASTO 1	205 mm   9 7/8"	300 kg/ 661 lb	402 x 80 x 41 mm   15 7/8" x 3 1/8" x 1 5/8"
ALMO 1	350 mm   13 3/4"	400 kg/ 882 lb	858 x 80 x 41 mm   33 3/4" x 3 1/8" x 1 5/8"
AQTO 1	265 mm   10 3/8"	300 kg/ 661 lb	550 x 80 x 41 mm   21 5/8" x 3 1/8" x 1 5/8"
ABTO 1	350 mm   13 1/4"	450 kg/ 992 lb	854 x 212 x 50 mm   33 5/8" x 8 3/8" x 2"
AMTO 1	209 mm   8 1/4"	450 kg/ 992 lb	

## HAND TRUCKS ▶ KEY FEATURES

- ★ Displaced center of gravity and robust tubular construction.
- ★ Special pneumatic wheels for high-load capacity.



HAND TRUCK

TRANSPORT TRUCK

FRONT TROLLEY

PRODUCT CODE	Height	Blade Dimensions	Rubber Wheel	Working Load Limit
AHT500	338 mm   13 1/4"	580 x 210 mm   22 7/8" x 8 1/4"	265 mm   10 3/8"	500 kg/ 1102 lb
AHT750	1260 mm   49 5/8"	420 x 80 mm   16 1/2" x 3 1/8"	250 mm   9 7/8"	750 kg/ 1653 lb
AHT750H	1360 mm   53 1/2"	420 x 60 mm   16 1/2" x 2 3/8"	400 mm   15 3/4"	750 kg/ 1635 lb
AHPT750	1308 mm   51 1/2"	360 x 100 mm   14 1/8" x 4"	350 mm   13 3/4"	750 kg/ 1635 lb
AHPT1000	1585 mm   62 3/8"	420 x 90 mm   16 1/2" x 3 1/2"	400 mm   15 3/4"	1000 kg/ 2204 lb
AHPT1000A	1585 mm   62 3/8"	420 x 90 mm   16 1/2" x 3 1/2"	400 mm   15 3/4"	1000 kg/ 2204 lb
AHTC750	1400 mm   55 1/8"	355 x 130 mm   14" x 5 1/8"	265 mm   10 3/8"	750 kg/ 1635 lb
AHTC1500	1734 mm   68 1/4"	470 x 120 mm   18 1/2" x 4 3/4"	400 mm   15 3/4"	1250 kg/ 2756 lb
AFTO 1	1520 mm   59 7/8"	-	260 mm   10 1/4"	1250 kg/ 2756 lb

# 06

# JIB CRANES

## PORTABLE GANTRY CRANES ▶ KEY FEATURES

- ★ Lightweight, portable, stable under load.
- ★ Attached to lifting equipments, the crane makes it easy to lift heavy loads.
- ★ Ability to assemble and disassemble easily and quickly.



PORTABLE GANTRY CRANE

AGC-1000

PRODUCT CODE	AGC-1000
Maximum Span	3100 mm   122"
Working Load Limit	1000 kg/ 2204 lb



**SCAN HERE**  
To visit the Category

## JIB CRANES ▶ KEY FEATURES

- ★ Highly durable design, 180 - 360° rotation.
- ★ Can be combined with a vacuum lifter and an electric hoist.



AJCAWM

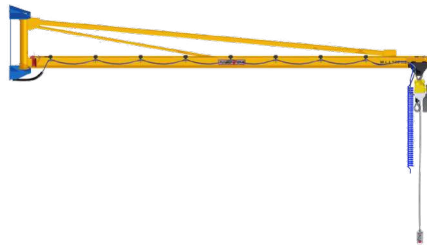

AJCOWM

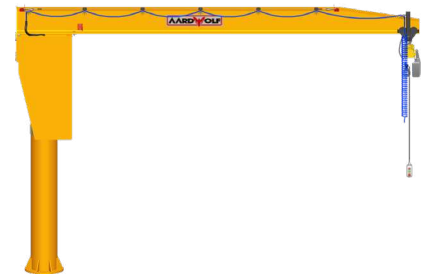

AJCPIL

PRODUCT CODE	AJCAWM	AJCOWM	AJCPIL
Maximum Span	5000 mm   196 7/8"	6000 mm   236 1/4"	6000 mm   236 1/4"
Working Load Limit	500 kg/ 1102 lb	500 kg/ 1102 lb	2000 kg/ 4408 lb



CMA01



AJCOCM

PRODUCT CODE	CMA01	AJCOCM
Maximum Spans	7000 mm   275 9/16"	7000 mm   275 9/16"
Working Load Limit	500 kg/ 1102 lb	1000 kg/ 2204 lb



**AARDWOLF  
ELECTRIC HOIST**

**AHKS-600**

★ Working Load Limit  
500 kg/ 1102 lb



**HITACHI  
ELECTRIC HOIST**

**AHHI-1S**

★ Working Load Limit  
1000 kg/ 2204 lb

## COUNTERBALANCE CRANE

### COUNTERBALANCE CRANE

#### ▶ KEY FEATURES

- ★ An integral counterweight.
- ★ An easy-to-operate hydraulically lifted extending boom.

Extended	Length: 1700 mm   66 7/8" Height: 2760 mm   108 5/8"
Working Load Limit	540 kg/ 1190 lb



# LIGHT LOAD CRANES

## FLOOR-MOUNTED JIB CRANES ▶ KEY FEATURES

- ★ Mounted firmly to floor, over-braced design, 270-degree rotation.

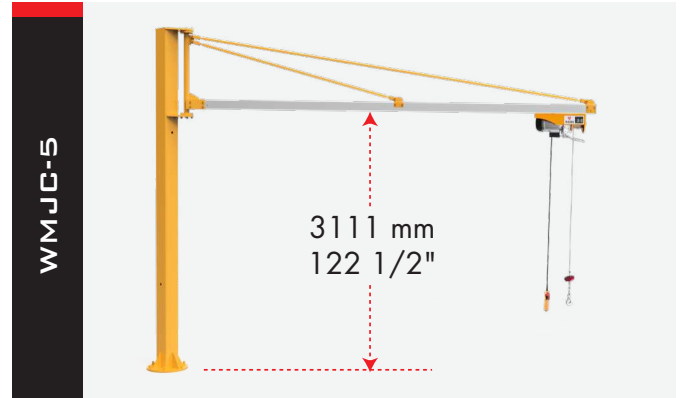
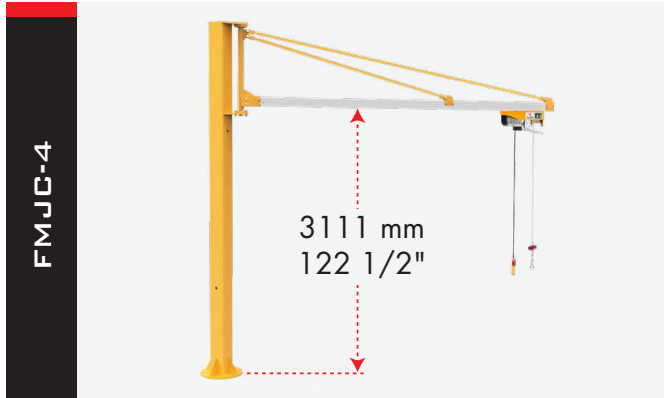

PRODUCT CODE	Standard Arm Length	Standard Crane Height	Working Load Limit
FMJC-4	4000 mm   157 1/2"		200 kg/ 441 lb
FMJC-5	5000 mm   196 7/8"	4000 mm   196 7/8"	150 kg/ 331 lb

## WALL-MOUNTED JIB CRANES

### ▶ KEY FEATURES

- ★ Mounted securely to a wall or structural column.
- ★ Over-braced design, 270-degree rotation.

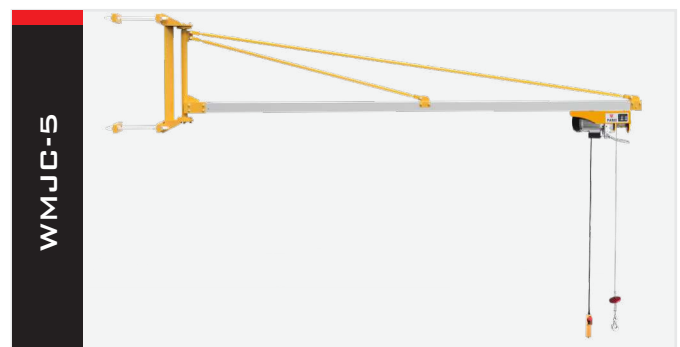

PRODUCT CODE	Arm Length	Working Load Limit
WMJC-3	3041 mm   119 3/4"	250 kg/ 551 lb
WMJC-4	4041 mm   159 1/8"	200 kg/ 441 lb
WMJC-5	5041 mm   198 1/2"	150 kg/ 331 lb

# A-FRAMES

# 07



The Aardwolf Transport Frames are the most versatile frames on the market. Precision laser cutting and robotic welding ensure your frame is strong and reliable

**BEST  
SELLER**



**SCAN HERE**  
To visit the Category

TF2440

PRODUCT CODE	Width of Each Side	Working Load Limit	Net Weight
TF2440	268 mm   10 1/2"	2500 kg/ 5511 lb	207 kg/ 456 lb

# TRANSPORT FRAMES

## TF-SERIES ► KEY FEATURES

- ★ Large counter lever with wheels makes manual moving of loaded frame easy.
- ★ Built-in forklift receivers on all sides for lifting by forklift.
- ★ The base and uprights come with replaceable white rubber to prevent markings and scratches.



TF2000



TF3050



TF3050H

PRODUCT CODE	Width of Each Side	Working Load Limit	Net Weight
TF2000	268 mm   10 1/2"	2500 kg/ 5511 lb	182 kg/ 401 lb
TF3050	268 mm   10.6"	2500 kg/ 5511 lb	239 kg/ 527 lb
TF3050H	207 mm   8"	2500 kg/ 5511 lb	260 kg/ 573 lb

## QP-SERIES ► KEY FEATURES

- ★ Load-bearing surfaces are topped with rubber to prevent scratches and damage to goods being transported.
- ★ Wheels with brakes to ensure safety in operation.
- ★ Locking bars are mounted in slotted holes on the bottom for storing slabs.



PRODUCT CODE	Width of Each Side	Working Load Limit	Net Weight
AF1850QP	295 mm   11 5/8"	1100 - 4000 kg/ 2425 - 8818 lb	246 kg/ 542 lb
AF2440QP	323 mm   11 5/8"	2000 - 4000 kg/ 4409 - 8818 lb	281 kg/ 619 lb

# A-FRAMES

## SINGLE SIDED TRUCK RACKS ► KEY FEATURES

- ★ Rubber strips mounted on the bottom and back support to protect materials from damage.
- ★ Heavy-duty construction is fabricated with 40 mm (1 5/8") square steel tubing.



PRODUCT CODE	Width of Each Side	Working Load Limit	Net Weight
SSTR-2000	388 mm   15 1/4"	2500 kg/ 5511 lb	137 kg/ 302 lb
SSTR-2440	388 mm   15 1/4"	2500 kg/ 5511 lb	161 kg/ 355 lb

## WOLF RACKS ► KEY FEATURES

- ★ Includes a number of modular A-frames formed from 2 mm sheet metal secured to one another.
- ★ Frame-bearing surfaces are rubber-topped.
- ★ Lightweight but firm and can be easily and quickly assembled and disassembled.

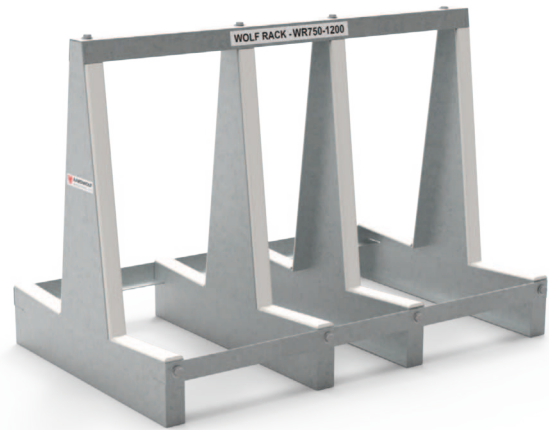

PRODUCT CODE	Width of Each Side	Working Load Limit	Net Weight
WR750-1200	276 mm   10 7/8"	1000 kg/ 2204 lb	37 kg/ 81.6 lb
WR1270-1200	230 mm   9"	1000 kg/ 2204 lb	48 kg/ 106 lb
WR1270-1600	230 mm   9"	1000 kg/ 2204 lb	65 kg/ 143 lb
WR1270-2000	230 mm   9"	1200 kg/ 2645 lb	75 kg/ 165 lb
WRP1270-1200	230 mm   9"	1000 kg/ 2204 lb	51 kg/ 112 lb
WRP1270-1600	230 mm   9"	1000 kg/ 2204 lb	70 kg/ 154 lb
WRP1270-2000	230 mm   9"	1200 kg/ 2645 lb	83 kg/ 183 lb

# A-FRAMES

## SLAB BUGGY ▶ KEY FEATURES

- ★ Swivel wheels with hinge bolts.
- ★ Pneumatic rear wheels for easy control.
- ★ Rubber is topped on the frame to prevent scratches.



PRODUCT CODE	Width of Each Side	Working Load Limit	Net Weight
SBSS	204.5 mm   8"	600 kg/ 1323 lb	48.8 kg/ 99 lb
SBDS	204.5 mm   8"	750 kg/ 1653 lb	61.7 kg/ 136 lb
SBSS-E	204.5 mm   8"	400 kg/ 882 lb	40.7 kg/ 90 lb

## FOLDING 'A' FRAMES & STORAGE 'A' FRAMES ▶ KEY FEATURES



FAF SERIES

### FOLDING 'A' FRAMES

- ★ For mobility and transport. The frame can be folded when not in use, saving space.

### STORAGE 'A' FRAMES

- ★ Ideal for fixed storage. The frame is constructed for the stationary storage of slabs.



SAF SERIES

PRODUCT CODE	Working Load Limit	Net Weight
--------------	--------------------	------------

FOLDING 'A' FRAMES		
FAF-1600	6000 kg/ 13228 lb	223 kg/ 492 lb
FAF-1800	6000 kg/ 13228 lb	243 kg/ 536 lb
FAF-2100	7500 kg/ 16534 lb	281 kg/ 619 lb

STORAGE 'A' FRAMES		
SAF01	15000 kg/ 33069 lb	120 kg/ 264 lb
SAF02-S	12000 kg/ 26455 lb	53.8 kg/ 119 lb
SAF02-HD	15000 kg/ 33069 lb	78 kg/ 172 lb
SAF03 PLUS	15000 kg/ 33069 lb	102.5 kg/ 226 lb

# A-FRAMES

## DRYWALL TROLLEYS ► KEY FEATURES

- ★ Swivel casters with brake.
- ★ Two fixed casters and two rotary casters for easy control.
- ★ The smart arrangement of parts to increase stability.



DWT-1180



DWT-1180P



PRODUCT CODE	Width of Each Side	Working Load Limit	Net Weight
DWT-1180	307 mm   12 1/8"	1000 kg/ 2204 lb	29 kg/ 64 lb
DWT-1180P	300 mm   11 3/4"	1000 kg/ 2204 lb	34 kg/ 75 lb

## BASE ONLY ► KEY FEATURES

- ★ Ideal for transporting and storing material within the factory or building sites.
- ★ Heavy-duty wheels and a handle allow easy maneuvering on various surfaces.



BASE ONLY SERIES

PRODUCT CODE	Bdff200	Bdff400	BDFH200
Working Load Limit	1000 kg/ 2204 lb	1000 kg/ 2204 lb	750 kg/ 1653 lb
Net Weight	25 kg/ 55 lb	68 kg/ 150 lb	43 kg/ 95 lb

# A-FRAMES

## DEMOUNTABLE FRAMES ▶ KEY FEATURES

- ★ Designed for secure transportation of materials.
- ★ Protective rubber layers ensure materials are protected from damage.
- ★ Stick-out handle facilitates easy handling and transportation of materials.



**DFF2350PC**



**DFH200**



**DFF200**



**DFF400**



**DFF1500PC**

PRODUCT CODE	Width of Each Side	Working Load Limit	Net Weight
DFH200	304 mm   12"	750 kg/ 1653 lb	92 kg/ 202 lb
DFF200	300 mm   11 3/4"	1000 kg/ 2204 lb	102 kg/ 225 lb
DFF400	300 mm   11 3/4"	1000 kg/ 2204 lb	176 kg/ 388 lb
DFF1500PC	361 mm   14 1/4"	1000 kg/ 2204 lb	127.5 kg/ 281 lb
DAF2350PC	212 mm   8 3/8"	1500 kg/ 3307 lb	178 kg/ 392 lb

## TOP FRAME ONLY ▶ KEY FEATURES

- ★ Ideal for transporting and storing material within the factory or building sites.
- ★ Fits inside a standard pick-up truck.
- ★ Rubber-topped frame surfaces for preventing scratches and damage.



**TOP FRAME ONLY SERIES**

PRODUCT CODE	Width of Each Side	Working Load Limit	Net Weight
TFDFF24	300 mm   11 3/4"	1000 kg/ 2204 lb	72.8 kg/ 161 lb
TFDFH2	304 mm   12"	750 kg/ 1653 lb	45 kg/ 99 lb
TFDFF1500	361 mm   14 1/4"	1000 kg/ 2204 lb	75 kg/ 165 lb

# SLAB & BUNDLE RACKS

# 08



Aardwolf provides the Slab Rack Kits, which contains a pair of galvanized steel rails 3 meters long, with galvanized square steel tube posts and steel post bases.

## SCAN QR CODES

For using our Slab Rack Calculator

App



Web



**ASR 1600**

Square tube post:  
50 x 50 x 1600 mm / 2" x 2" x 63"

# SLAB & BUNDLE RACK KITS

## KEY FEATURES

- ★ Designed for storing large quantities of slabs.
- ★ These racks are the best storage solution, offering cost-saving and economic effects for users.
- ★ Aardwolf has developed a simple calculator for users to calculate the slab storage capacity.

## SLAB RACKS

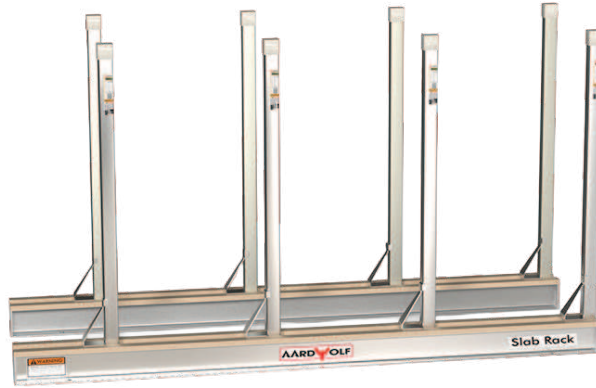

PRODUCT CODE	Qty	ASR 1200	ASR 1400	ASR 1800
Galvanized steel rail	2	2979 x 164 x 165 mm   117 1/4" x 6 1/2" x 6 1/2"		
Square tube post	16	50 x 50 x 1200 mm 2" x 2" x 47 1/4"	50 x 50 x 1400 mm 2" x 2" x 55 1/8"	50 x 50 x 1600 mm 2" x 2" x 63"
Steel post base	14	1200 - 1400mm 47 1/4" - 55 1/8"	1200 - 1400mm 47 1/4" - 55 1/8"	1600 - 1800mm 63" - 70 7/8"
Rectangular rubber cap	16	52 x 52 mm/ 2" x 2"		

## BUNDLE RACKS



PRODUCT CODE	Qty	ABR 1200	ABR 1400	ABR 1600
Galvanized steel rail	2	3013 x 167 x 140 mm/ 118.6" x 6.6" x 5.5"		
Square tube post	8	100 x 50 x 1200 mm 4" x 2" x 47 1/4"	100 x 50 x 1400 mm 4" x 2" x 55 1/8"	100 x 50 x 1600 mm 4" x 2" x 63"
Steel post base	6	1200 - 1400mm 47 1/4" - 55 1/8"	1200 - 1400mm 47 1/4" - 55 1/8"	1600 - 1800mm 63" - 70 7/8"
Rectangular rubber cap	8	100 x 50 mm/ 4" x 2"		

# SLAB & BUNDLE RACKS

## BUNDLE RACK 3M RUBBER-TOPPED

### ► KEY FEATURES

- ★ **Rubber-Topped Surface:** Improves friction and protects against chipping and slippage.
- ★ **Heavy-Duty Steel Construction:** Built from galvanized steel with a yield strength of 345 MPa.
- ★ **Customizable Post Positioning:** Rectangular holes allow flexible post arrangement along the rail.
- ★ **Post Height Options:** Compatible with post heights of 1200, 1400, and 1600 mm.
- ★ **Optimized for 4° Lean Storage:** Supports safe and efficient slab stacking at an industry-standard angle.



PRODUCT CODE	Rail Length	Tube Post	Net Weight of Each Rail
ASR02	3000 mm/ 118 1/8"	50 x 50 mm/ 2" x 2"	67.7 kg/pcs   149 lb /pcs
ABR02	2925 mm/ 115 1/8"	100 x 50 mm/ 4" x 2"	64.2 kg/pcs   141.5 lb /pcs

GET THE AWESOME MOBILE APP

FOR

## FABRICATOR

SLAB STORAGE CALCULATOR

The simple, accurate, and practical calculations to guarantee your safety on any project



Available for **DOWNLOAD!**

GET IT ON
Download on the

WARNING: Do not use this app to calculate the storage capacity of posts produced by others, unless the posts have the same wall profile and steel yield strength as the **AARDWOLF** posts

SLAB RACK Calculator

info@aardwolf.com.au

www.aardwolf.com.au

## SLAB RACK 3M RUBBER-TOPPED



### STEEL POST BASE

SPB1214	1200 - 1400 mm
SPB1618	1600 - 1800 mm

# SLAB & BUNDLE RACKS

## SLAB & BUNDLE RACK POSTS ▶ KEY FEATURES

PRODUCT CODE	Post Dimension
FGRO6	50 x 50 x 700 mm/ 2" x 2" x 27 1/2"
ASRP800	50 x 50 x 800 mm/ 2" x 2" x 31 1/2"
ASRP1200	50 x 50 x 1200 mm/ 2" x 2" x 47 1/4"
ASRP1400	50 x 50 x 1400 mm/ 2" x 2" x 55 1/8"
ASRP1600	50 x 50 x 1600 mm/ 2" x 2" x 63"
ASRP1800	50 x 50 x 1800 mm/ 2" x 2" x 70 7/8"
ABRP1200	100 x 50 x 1200 mm/ 4" x 2" x 47 1/4"
ABRP1400	100 x 50 x 1400 mm/ 4" x 2" x 55 1/8"
ABRP1600	100 x 50 x 1600 mm/ 4" x 2" x 63"



## OTHER SLAB & BUNDLE RACKS



PRODUCT CODE	Rail Length	Tube Post	Net Weight of Each Rail
ARR01	3000 mm/ 118 1/8"	High 740 mm / 30"	23.8 kg   184.7 lb
AFGR	2400 mm/ 94 1/2"	50 x 50 mm/ 2" x 2"	24 kg/pcs   53 lb /pcs
AWRO1P	2400 mm/ 94 1/2"	50 x 50 mm/ 2" x 2"	36 kg/pcs   79 lb /pcs
ASRO1	3000 mm/ 118 1/8"	50 x 50 mm/ 2" x 2"	68 kg/pcs   150 lb /pcs
ABRO1	2925 mm/ 115 1/8"	100 x 50 mm/ 4" x 2"	66 kg/pcs   145 lb /pcs
ARR01	3000 mm/ 118 1/8"	Height: 740 mm/ 29 1/8"	84 kg/pcs   185 lb /pcs

# FORKLIFT EQUIPMENT

# 09



**SCAN HERE**  
To visit the Category

All Forklift Booms are made from high-grade Australian rectangular tube steel, AS1163-450 LO, which ensures strength, reliability, and safety.



**FB1-2720**

PRODUCT CODE	Manual Telescope	Increment	Working Load Limit
FB1-2720	1610 - 2724 mm 63 3/8" - 107 1/4"	557 mm   21 7/8"	Retracted: 1500 kg/ 3307 lb Extended: 500 kg/ 1102 lb

# FORKLIFT BOOMS



## KEY FEATURES

- ★ The boom is firmly secured onto fork blades by two bolts located at the back of each fork pocket and restraint pins.
- ★ Easy to adjust lengths for many different load capacity levels.



### FLEXIBLE CONNECTION

Works with forklifts and lifting clamps to move slabs.

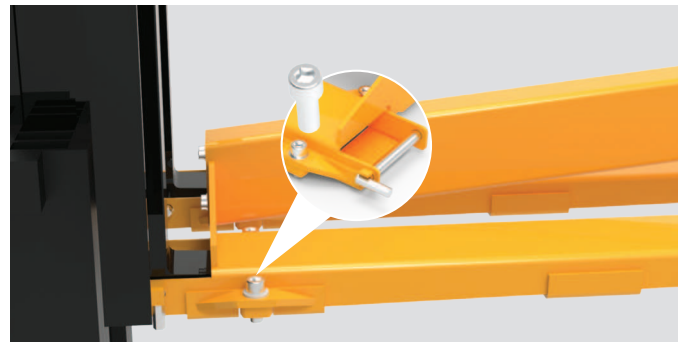

### EASY TO ASSEMBLE

The Boom is fixed firmly to forklift by Hexagon head screws.

PRODUCT CODE	Manual Telescope	Increment	Working Load Limit
FB2-3580	2107 - 3580 mm 83" - 141"	491 mm   119 3/8"	Retracted: 1500 kg/ 3307 lb Extended: 700 kg/ 1543 lb
FB3-5380	2196 - 5380 mm 86 1/2" - 211 3/4"	796 mm   31 3/8"	Retracted: 2400 kg/ 5291 lb Extended: 300 kg/ 661 lb
FB4-4800	2800 - 4800 mm 110 1/4" - 189"	1000 mm   39 3/8"	Retracted: 3000 kg/ 6614 lb Extended: 1000 kg/ 2204 lb
FB2LP-3600	2121 - 3603 mm 83 1/2" - 141 7/8"	494 mm   19 1/2"	Retracted: 2400 kg/ 5291 lb Extended: 600 kg/ 1323 lb
FB3LP-5420	2210 - 5410 mm 87" - 213"	800 mm   31 1/2"	Retracted: 2400 kg/ 5291 lb Extended: 300 kg/ 661 lb
PFB1-2600	1500 - 2600 mm 59" - 102 3/8"	560 mm   22"	Retracted: 1500 kg/ 3307 lb Extended: 500 kg/ 1102 lb
PFB2-3450	1930 - 3412 mm 76" - 134 3/8"	494 mm   19 1/2"	Retracted: 1500 kg/ 3307 lb Extended: 600 kg/ 1323 lb

# FORKLIFT EQUIPMENT

## AARDWOLF DOUBLE FORKLIFT BOOM ▶ KEY FEATURES

- ★ The open hooks are designed for the quick and easy hooking of flat web sling eyes.
- ★ The inner sliding hook can be slid to all holes on the forks to adjust the distance quickly.
- ★ Optimizes work efficiency, reduces the labor force, and is safer.



PRODUCT CODE	Adjustable Connection Bar Distance	Working Load Limit	Net Weight
DFB2-5000	300 - 1300 mm   11 3/4" - 51 1/8"	5000 kg   11023 lb	657 kg/ 1448 lb

## FORK EXTENSIONS ▶ KEY FEATURES

- ★ Extends working length of forklifts.



### FORK EXTENSION SERIES

PRODUCT CODE	Working Load Limit	Working Length	Net Weight
FES-1500	1500 kg/ 3307 lb	1500 mm   59"	46 kg/ 101 lb
FES-2000	1500 kg/ 3307 lb	2000 mm   78 3/4"	62 kg/ 137 lb
FES-2500	1500 kg/ 3307 lb	2500 mm   98 3/8"	86 kg/ 190 lb
AFE-1500	2500 kg/ 5511 lb	1500 mm   59"	74 kg/ 163 lb
AFE-2000	2500 kg/ 5511 lb	2000 mm   78 3/4"	91 kg/ 201 lb
AFE-2500	2500 kg/ 5511 lb	2500 mm   98 3/8"	122 kg/ 269 lb

# AARDWOLF COMBO BOOM, SWIVEL & LIFTING CLAMP

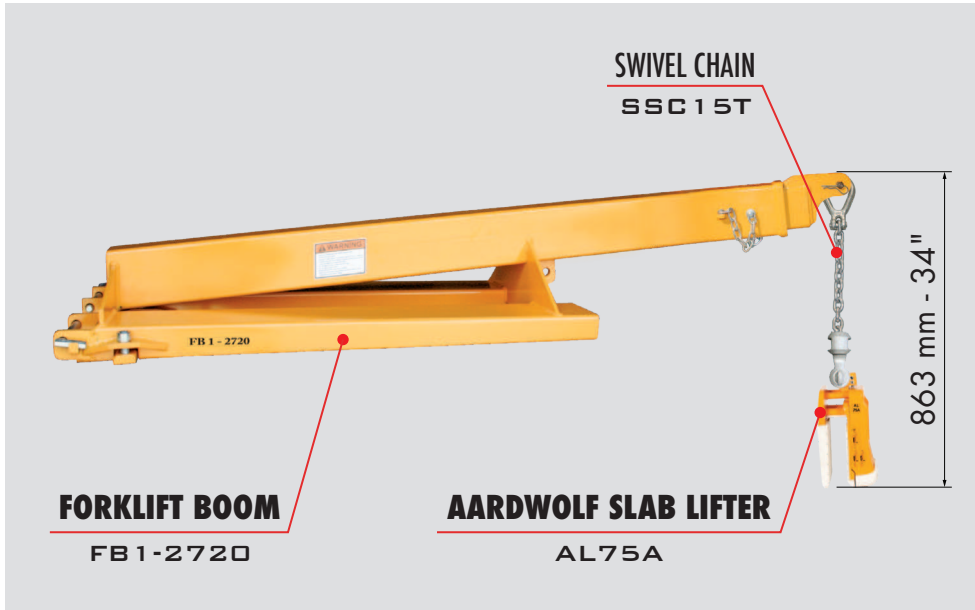

## COMBO 1

Forklift Boom connects with Aardwolf Slab Lifter via Swivel Chain.



## COMBO 2

Forklift Boom connects with Aardwolf Slab Lifter via Swivel Hook.

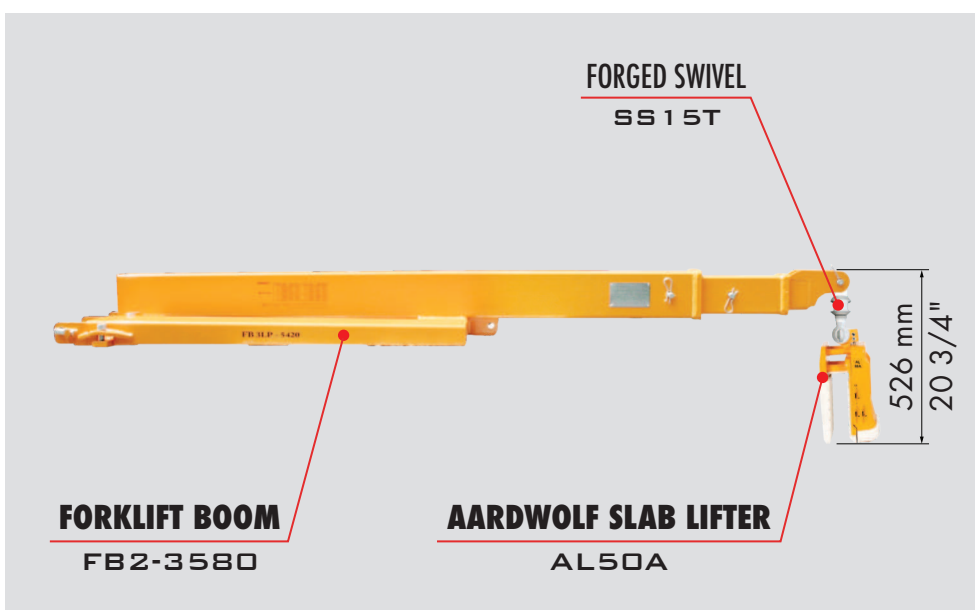

## COMBO 3

Forklift Boom connects with Aardwolf Slab Lifter via Forged Swivel.

# FORK ATTACHMENTS & ACCESSORIES



Product Name	PRODUCT CODE	Working Load Limit	Net Weight
Twister	MSS02	1200 kg/ 2646 lb	19.4 kg/ 40.7 lb
Single Fork	FHASF1	1500 kg/ 3307 lb	7.5 kg/ 16.5 lb
Double Fork	FHADDF2	3000 kg/ 6614 lb	13 kg/ 29 lb
Swivel Hook Autolock	SHA3.15T	3150 kg/ 6945 lb	2.1 kg/ 4.6 lb
Swivel Hook ( Alloy steel )	SH1.5T	1500 kg/ 3307 lb	0.62 kg/ 1.36 lb
Swivel Hook ( Alloy steel )	SH3T	3000 kg/ 6614 lb	1.4 kg/ 3.1 lb
Swivel Hook ( Alloy steel )	SH7T	7000 kg/ 15432 lb	4 kg/ 9 lb
Bow Shackle	BS1.3T	1500 kg/ 3307 lb	0.2kg/ 0.44 lb
Bow Shackle	BS3T	3250 kg/ 7165 lb	0.2kg/ 0.44 lb
Forged Aluminium Swivel	SS1.5T	1500 kg/ 7165 lb	0.5 kg/ 1 lb
Combo Swivel-Chain-Lifting Lug	SSC1.5T	1500 kg/ 3307 lb	1.5 kg/ 3.3 lb
Collapsible Safety Cage	ACSC	250 kg/ 551 lb	155 kg/ 342 lb

# 10

# WORKBENCHES & STANDS



With its innovative design, the Aardwolf Kitchen Installation Cart revolutionizes stone transportation and installation.



**SCAN HERE**  
To visit the Category

- ★ Material: Aluminium alloy
- ★ Open Size: 3000 mm (L) x 1000 mm (W)  
118 1/8" x 39 3/8"
- ★ Foot Height: 450 - 650 mm (Adjustable)  
17 3/4" - 25 5/8"
- ★ Working Load Limit: 500 kg / 1102 lb



**SCAN ME**

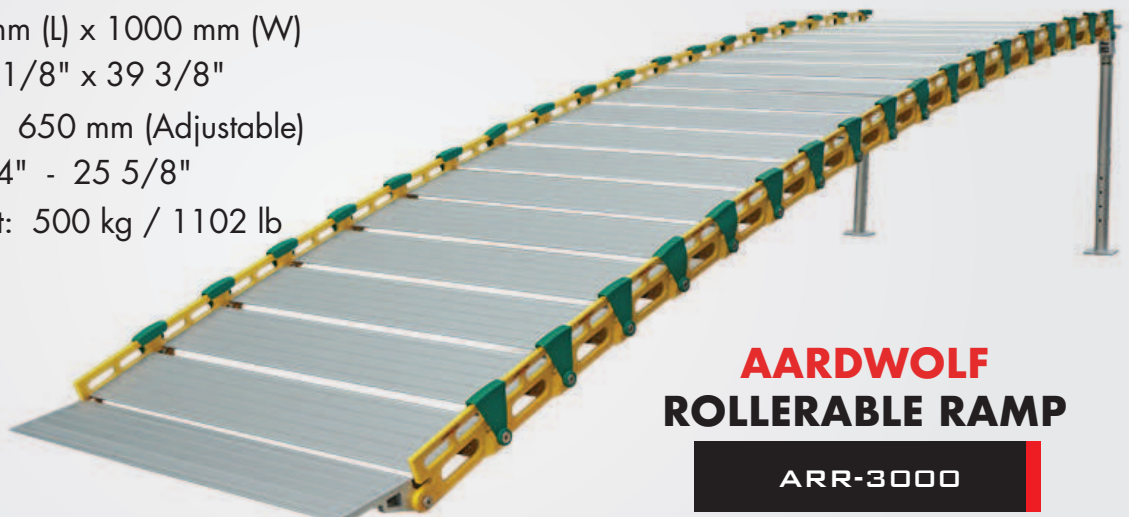

**AARDWOLF**  
**ROLLERABLE RAMP**

**ARR-3000**

Option Available: We also offer the ARR-1500 model with an open size of L1500 x W1000 mm and adjustable foot height ranging from 200 to 300 mm.

# KITCHEN INSTALLATION CARTS

## KEY FEATURES

- ★ Equipped with transfer bearings located on the table surface, the countertop can be rolled into place without friction and strain.
- ★ The product comprises three actuators for lowering, lifting, and tilting workpieces.
- ★ Includes both fixed and adjustable sections to accommodate countertops of various sizes.
- ★ Powered by 24V rechargeable Lithium - Ion battery.



**AKIC**



**PRO VERSION**

**AAKIC**



### VERSATILE MOVEMENT CAPABILITY

The cart is designed to lower, lift, and roll large workpieces, aiding in the final placement of countertops.



### WIRELESS REMOTE CONTROL

Enhances ease of use by allowing the operator to control the cart remotely.



### CONTROL BOX

It runs on a 24V rechargeable lithium-ion battery, providing reliable and long-lasting power.

PRODUCT CODE	Height of the Frame	Working Load Limit	Net Weight
AKIC	884.5 mm   34 7/8"	500 kg/ 1102 lb	147 kg/ 324 lb
AAKIC	929 - 1229 mm   36 5/8" - 48 3/8"	500 kg/ 1102 lb	112 kg/ 247 lb

# WORKBENCHES & STANDS

## WORK TABLES



PRODUCT CODE	Grip Range	Width With The Top	Working Load Limit
WT600	1906 x 600 mm   75" x 23 5/8"	679 mm   26 3/4"	500 kg/ 1102 lb
WT910	1906 x 915 mm   75" x 36"	950 mm   37 3/8"	500 kg/ 1102 lb

## ADJUSTABLE HEIGHT WORK TABLES



PRODUCT CODE	Grip Range	Height	Working Load Limit
AHWT600	1906 x 600 mm   75" x 23 5/8"	950 mm   37 3/8"	500 kg/ 1102 lb
AHWT910	1906 x 915 mm   75" x 36"	950 mm   37 3/8"	500 kg/ 1102 lb

## TRESTLES

TRESTLE SERIES

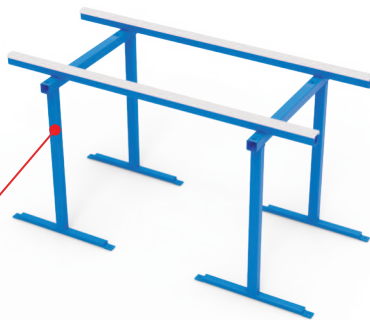

PRODUCT CODE	Height
AT765N / AT765W	765 mm   30 1/8"
AT855N / AT855W	855 mm   33 5/8"
Adjustable Width	100 mm   4"
Working Load Limit	1000 kg/ 2204 lb

## TABLE DOLLY

- ★ Working Load Limit: 500 kg/ 1102 lb



## FABRICATION STAND

- ★ Adjustable height: 915 - 1118 mm 36" - 44"
- ★ Working load limit: 650 kg | 1433 lb



# WORKBENCHES & STANDS

## FLIP TROLLEY



PRODUCT CODE	Working Load Limit
FT02	500 kg/ 1102 lb

## SCULPTURE TABLE

SCULPTURE TABLE SERIES



PRODUCT CODE	Working Load Limit
ST750 STH4L - STH5L	750 kg/ 1653 lb
ST1000	1000 kg/ 2204 lb

## FABRICATION TABLES



PRODUCT CODE	Working Load Limit
FT01	300 kg/ 661 lb
AEFT	200 kg/ 440 lb

## PREMIUM FABRICATION TABLES



PRODUCT CODE	Working Load Limit
PFT01	450 kg/ 992 lb

## EDGE POLISHING STANDS

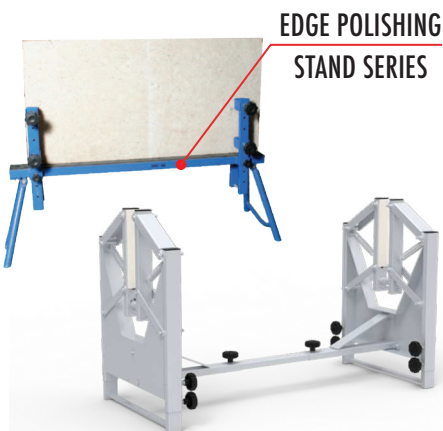

EDGE POLISHING STAND SERIES

PRODUCT CODE	Working Load Limit	Net Weight
PSALG01	0 - 60 mm/ 0 - 2 3/8"	33 kg/ 72.8 lb
VPF700	0 - 55 mm/ 0 - 2 1/8"	18.3 kg/ 40.3 lb
VPF1300	0 - 55 mm/ 0 - 2 1/8"	37.8 kg/ 83 lb
VPF1800	0 - 55 mm/ 0 - 2 1/8"	27.7 kg/ 61 lb
VPF2400	0 - 55 mm/ 0 - 2 1/8"	30 kg/ 66 lb
FV80	0 - 80 mm/ 0 - 3 1/8"	6.8 kg/ 15 lb
FVASL60	0 - 60 mm/ 0 - 2 3/8"	7 kg/ 15.4 lb

## OVERHEAD SWING ARM

★ This Overhead Swing Arm attaches to a wall or column where applications require air, power tools, or light to be positioned above the operator.

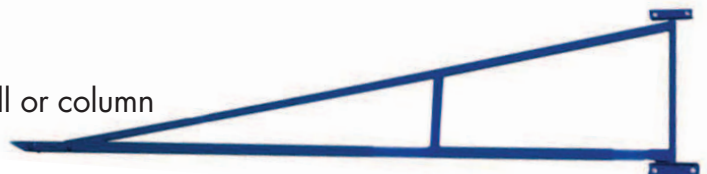

# 11

# COUNTERTOP TOOLS



**SCAN HERE**  
To visit the Category



## BATTERY JOINT SETTER

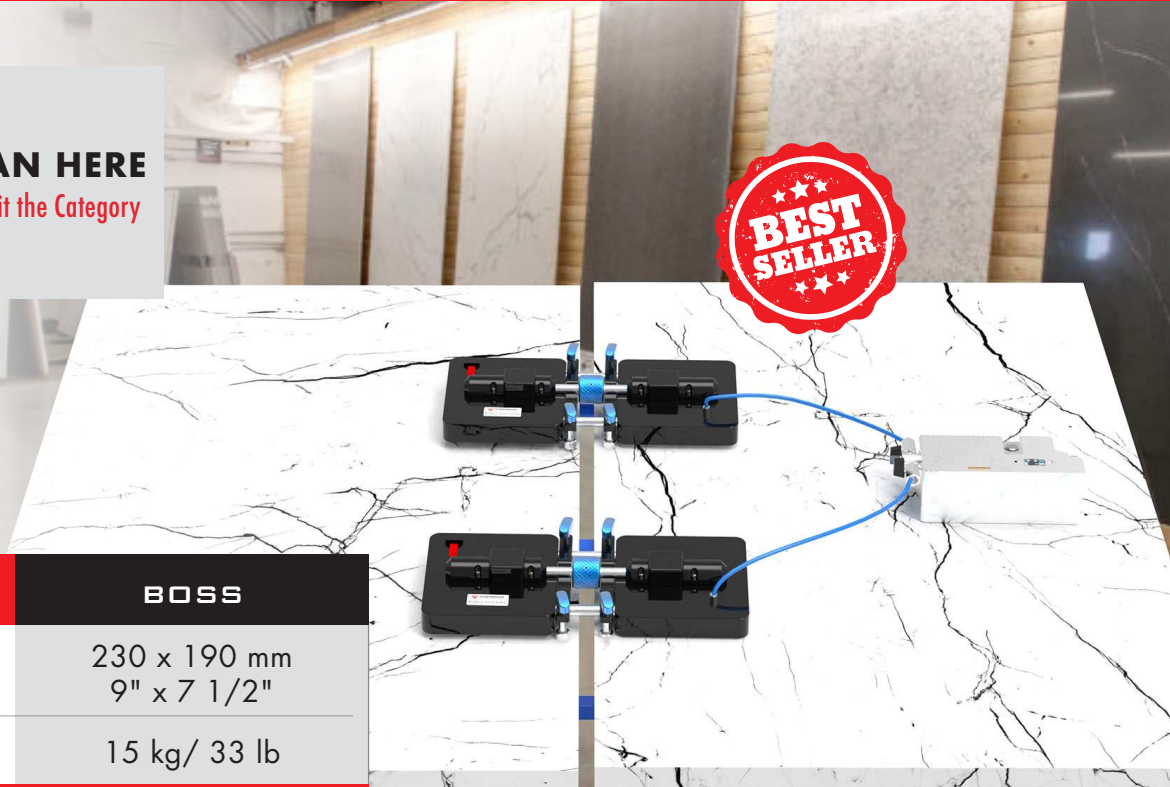

PRODUCT CODE	BOSS
Vacuum Base Size	230 x 190 mm 9" x 7 1/2"
Net Weight	15 kg/ 33 lb

## ELECTRIC JOINT SETTER



PRODUCT CODE	EOSS
Vacuum Base Size	230 x 190 mm 9" x 7 1/2"
Net Weight	16 kg/ 35 lb

## RATCHET SEAM SETTER



PRODUCT CODE	CTRSS 1
Cup Diameter	Ø203 mm 8"
Net Weight	6 kg/ 13 lb

# COUNTERTOP TOOLS



## SINKKLOCS

PRODUCT CODE	Working Load Limit	Net Weight
CTTS24	0 - 450 mm 0 - 17 3/4"	2 kg 4 lb
CTTS42	0 - 450 mm 0 - 17 3/4"	3.5 kg 8 lb

## ANTI-BREAKAGE BARS



PRODUCT CODE	Grip Range	Working Load Limit	Net Weight
CTTABB4	17 - 45 mm   5/8" - 2"	1220 mm   48"	8.4 kg/ 19 lb
CTTABB6	17 - 45 mm   5/8" - 2"	1830 mm   72"	12 kg/ 26 lb
CTTABB8	17 - 45 mm   5/8" - 2"	2440 mm   96"	14 kg/ 31 lb

## LAMINATION RAIL CLAMPS

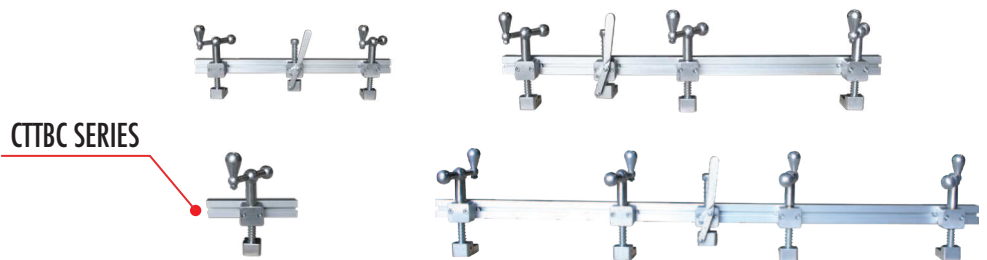

PRODUCT CODE	Grip Range	Length	Net Weight
CTTBC5	26 - 63 mm   1 - 2 1/2"	127 mm   5"	0.7 kg/ 1.5 lb
CTTBC10	26 - 63 mm   1 - 2 1/2"	245 mm   9 5/8"	1 kg/ 2 lb
CTTBC2	26 - 63 mm   1 - 2 1/2"	610 mm   24"	3 kg/ 7 lb
CTTBC3	26 - 63 mm   1 - 2 1/2"	915 mm   36"	4 kg/ 9 lb
CTTBC4	26 - 63 mm   1 - 2 1/2"	1220 mm   48"	5 kg/ 11 lb
CTTBC6	26 - 63 mm   1 - 2 1/2"	1830 mm   72"	6 kg/ 13 lb

# COUNTERTOP TOOLS



**SCAN HERE**  
To visit the Category

## AARDWOLF STONE MITER CLAMPS

PRODUCT CODE	ASMC250
Grip Range	50 - 250 mm 2" - 9 7/8"
Cup Diameter	Ø118 mm - 4 5/8"
Net Weight	10.2 kg/ 22.5 lb



## MITER CLAMPS VACUUM ASSISTED

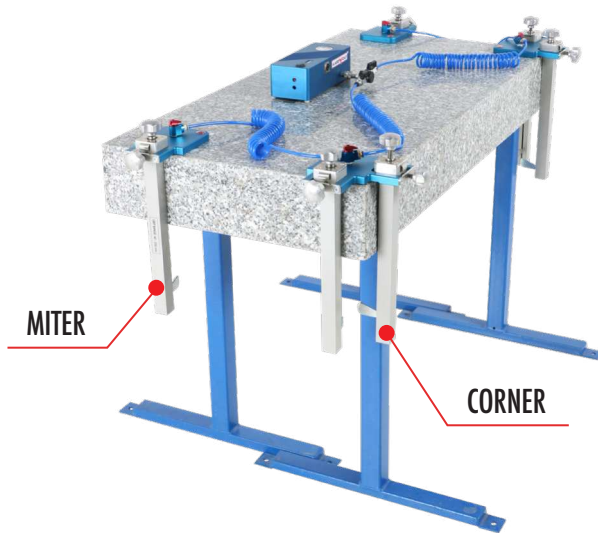

PRODUCT CODE	ABMC
Grip Range	50 - 250 mm 2" - 9 7/8"
Cup Diameter	Ø118 mm - 4 5/8"
Net Weight	12 kg/ 26.4 lb

## AARDWOLF CORNER CLAMP

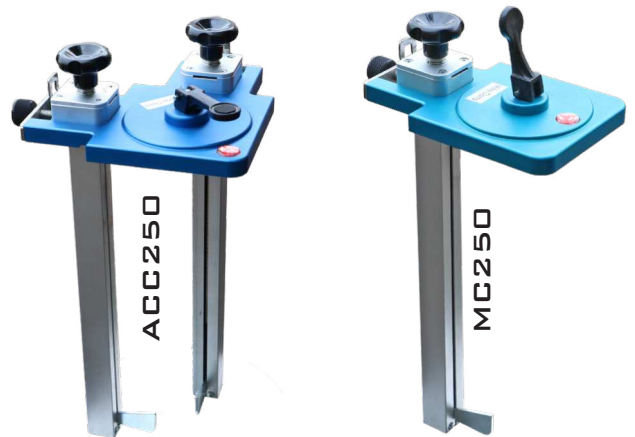

## AARDWOLF MITER CLAMP

CODE	ACC250	MC250
Grip Range	50 - 250 mm 2" - 9 7/8"	50 - 250 mm 2" - 9 7/8"
Net Weight	7 kg / 15 lb	3.9 kg / 9 lb



WHVC1



WHVC2

PRODUCT CODE	Suction Cups	Working Load Limit	Net Weight
WHVC	Ø200 mm   Ø7 7/8"	100 kg/ 220 lb	16 kg/ 35 lb
WOHVC	380 x 80 mm   15" x 3 1/8"	100 kg/ 220 lb	- kg/ - lb

## VACUUM PUMP WITH RESERVOIR

- ★ **Vacuum Pump:** 12V micro diaphragm gas pump, vacuum 80kpa, maximum flow 16L/min.
- ★ **Power Supply:** 12V 3.0 Ah li-ion, clip-in battery
- ★ **Vacuum Reservoir Capacity:** 770 cm<sup>3</sup> (47.3 in) ensures ample vacuum storage for continuous operation.



WBOSSR

WBOSSO

PRODUCT CODE	Number of pad	Suction Cups	Working load limit
WBOSSR	2	Ø200 mm   Ø7 7/8"	100 kg/ 220 lb
WBOSSO	2	380 x 80 mm   15" x 3 1/8"	100 kg/ 220 lb

# 12

# WORKSHOP EQUIPMENT

## WASTE BINS (POWDER COATED/ GALVANIZED)



Working Load Limit	Net Weight
<b>WB620PC - WB620G</b>	
1000 kg/ 2204 lb	170 kg/ 375 lb
<b>WB1000PC - WB1000G</b>	
1500 kg/ 3707 lb	221 kg/ 487 lb
<b>ADBB-2000</b>	
1500 kg/ 3707 lb	366 kg/ 807 lb

## SLUDGE DEHYDRATOR FILTER - ASDF1

- ★ **Fast Dehydration:** Efficiently collects and traps abrasive mud from stone processing.
- ★ **Cost-Effective:** One-step solution for separating and dewatering sludges.
- ★ **Durable:** Stainless steel construction ensures long-lasting performance.
- ★ **Low Maintenance:** No moving parts for minimal upkeep.
- ★ **Easy Operation:** Simple design with four key components for hassle-free use.

## CNC TOOLING CARTS & RACKS

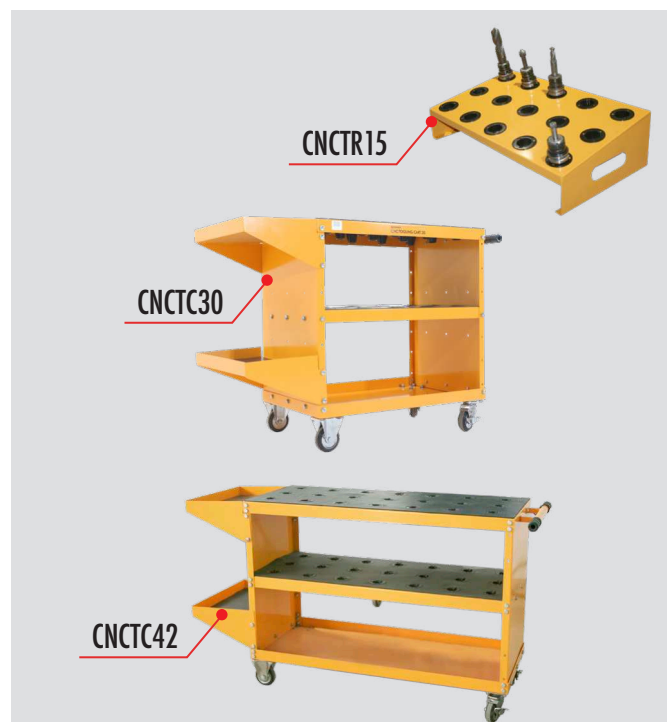

CODE	Tool Holder
CNCTR15	15
CNCTC30	30
CNCTC42	42



Dimensions	227 cm x 222 cm x 60 cm
Weight	280kg / 617 lb
Mud Holding Tank Capacity	550 liters/145 Gallons

# WORKSHOP EQUIPMENT

## SITE SAWS



SSM SERIES

CODE	SSM1200	SSM2000
Total Length	1370 mm 54"	1540 mm 60 5/8"
Net Weight	152 kg/ 335 lb	210 kg/ 463 lb

## MORTAR MIXERS



MML40

MML111

CODE	MML40	MML111
Drum capacity	40,000ml	106,000ml
Drum diameter	Ø424 mm Ø16 3/4"	Ø660 mm Ø26"

## DRILL MACHINE & DRILL STANDS

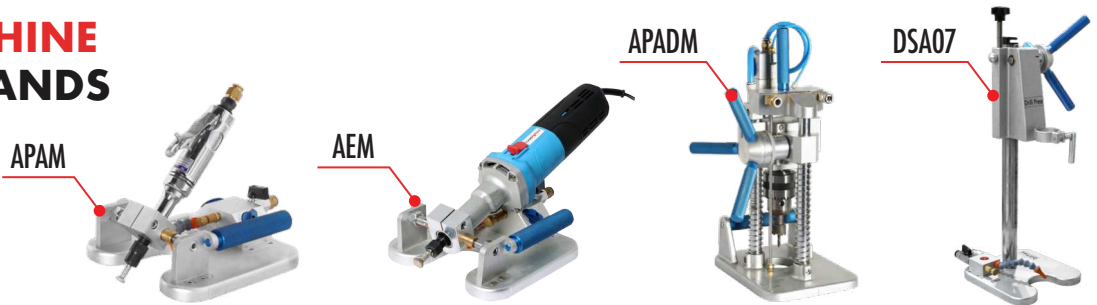

APAM

AEM

APADM

DSA07

PRODUCT CODE	No Load Speed	Drilling Bore Size	Net Weight
APAM	25000 RPM	6 mm   1/4"	3 kg/ 7 lb
EAM	30000 RPM	6 mm   1/4"	4 kg/ 9 lb
APADM	1200 RPM	50 mm   2"	10 kg/ 22 lb
DSA07	-	60 mm   2 3/8"	6 kg/ 13 lb

## WEDGE SPACER



## SNAIL LOCK



Diameter: 100mm/4"  
125mm/5"

## FIBERGLASS CUTTING STAND INCLUDING HAND SAW

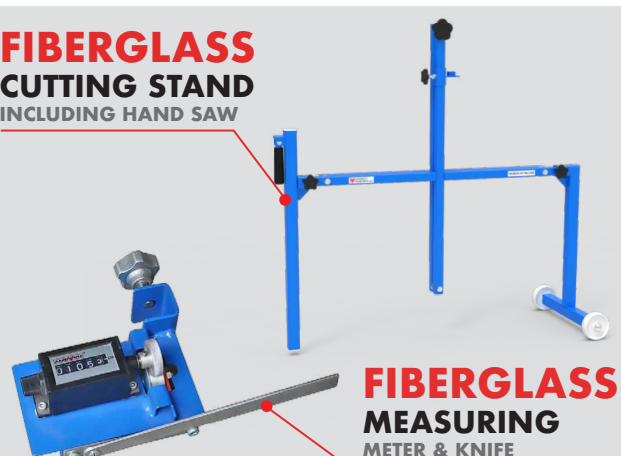

**FIBERGLASS MEASURING METER & KNIFE**

# WORKSHOP EQUIPMENT

## WATER SWIVELS

WATER SWIVEL SERIES



PRODUCT CODE	Specifications
WS01	F.M1/2" NPT
WS02	M14
WS03	M5/8" NPT
WS04	Ø10
WS05	M14 (F)
WS06	M5/8" NPT

## THREAD ADAPTORS

THREAD ADAPTOR SERIES



PRODUCT CODE	Specifications
WSDA01	M1/2" NPT - Ø10
WSDA02	M1/2" NPT - M14
WSDA03	M1/2" - M5/8" NPT
WSDA05	M14 - M14
WSDA06	M5/8" - M5/8" NPT

## DIAMOND CORE DRILLS

DIAMOND CORE DRILL SERIES



CODE	Specifications
M009031	Ø20 - M14 (F)
M009032	Ø22 - M14 (F)
M009033	Ø25 - M14 (F)
M009034	Ø32 - M14 (F)
M009035	Ø35 - M14 (F)
M009036	Ø38 - M14 (F)

## AARDWOLF ANCHOR BITS



CODE	Specifications
AAB 1/4	Ø6.35 mm   1/4"
AAB 3/16	Ø4.76 mm   3/16"
AAB 3/8	Ø9.5 mm   3/8"

## ELECTROPLATED CORE DRILLS

ELECTROPLATED CORE DRILL SERIES

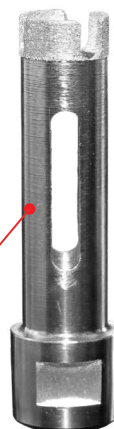

CODE	Specifications
M009037	Ø5 - M14 (F)
M009038	Ø10 - M14 (F)
M009039	Ø15 - M14 (F)
M009040	Ø20 - M14 (F)
M009041	Ø25 - M14 (F)
M009042	Ø30 - M14 (F)
M009043	Ø35 - M14 (F)
M009044	Ø40 - M14 (F)

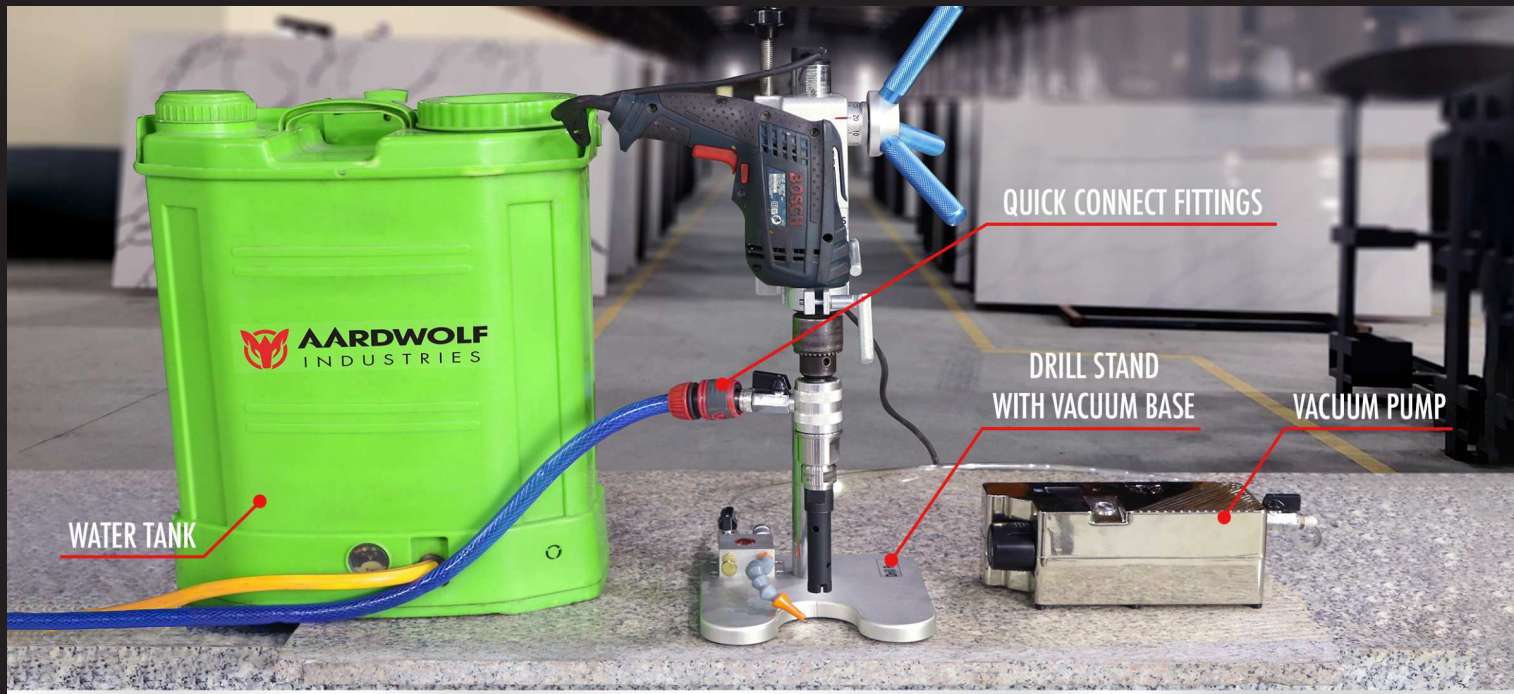

# ECONOMIC DRILL STAND TOOLS

## DRILL STAND WITH VACUUM BASE

**DSA07**

Lightweight, versatile drill stand with a robust integrated vacuum base.



## VACUUM PUMP

**AVPP03**

Vacuum pump with vacuum reservoir, which connects to drill stand.



## WATER TANK

Colors optional:

- Green
- Yellow
- Orange



## QUICK CONNECT FITTINGS

- ★ Quick Connection Mechanism
- ★ Leak Resistance
- ★ Versatility
- ★ Durability
- ★ User -Friendly Design





Get The Aardwolf Advantage

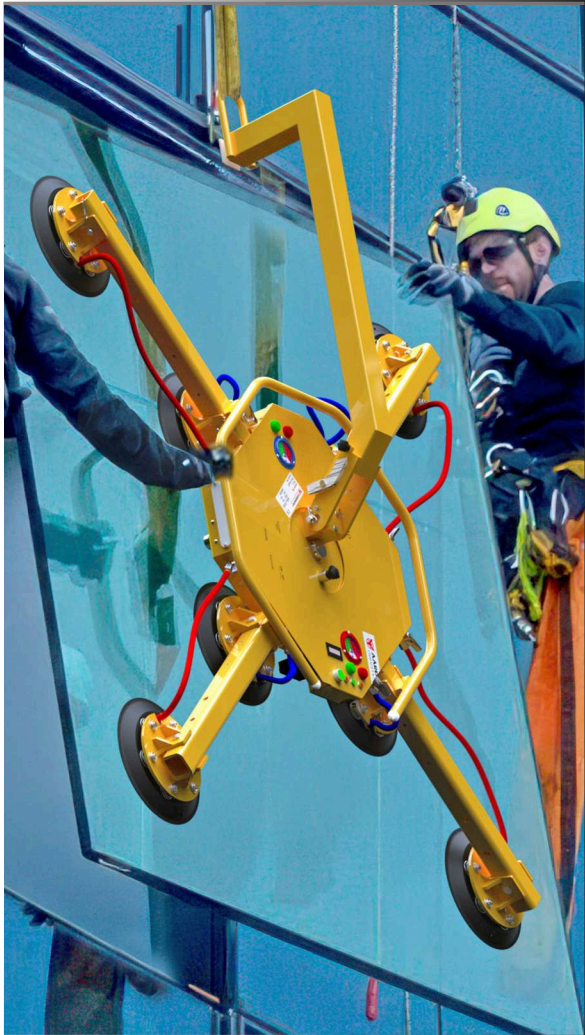

# CONTACT

 **AUSTRALIA**

1/5 Stanton Road, Seven Hills NSW 2147  
Tel: 02 9838 8427  
Email: [sales@toolrange.com.au](mailto:sales@toolrange.com.au)  
Web: [www.aardwolfaustralia.com](http://www.aardwolfaustralia.com)

 **BULGARIA**

Str.Usta Kolio Ficheto 33  
Tel: +359 887 933 754  
Email: [adrian@toolrange.com](mailto:adrian@toolrange.com)

 **GERMANY**

Schulze-Delitzsch-Weg 2, 33175 Bad Lippspringe  
Tel: 05252 8382830  
Email: [sales@toolrange.com.de](mailto:sales@toolrange.com.de)

 **INDIA**

Harmara Road, Industrial Area, Madanganj,  
Kishangarh, District- Ajmer, Rajasthan India 305801  
Tel: +91 73000 68444  
Email: [sales@aardwolf.co.in](mailto:sales@aardwolf.co.in)

 **USA**

9401 Norwalk Blvd, Santa Fe Springs, CA  
90670  
Tel: (562) 553-6050  
Email: [sales@aardwolfusa.com](mailto:sales@aardwolfusa.com)

 **VIETNAM**

1B, An Phu, Thuan An City, Binh Duong Province,  
Vietnam  
Tel: +84 931 707 793  
Email: [info@aardwolf.com.au](mailto:info@aardwolf.com.au)  
Web: [www.aardwolf.com.au](http://www.aardwolf.com.au)



AARDWOLF PRODUCT VIDEO:  
[www.youtube.com/@Aardwolf.English](http://www.youtube.com/@Aardwolf.English)

FOLLOW US:    

@Marketing Department Designed.