

LIFTING EQUIPMENT

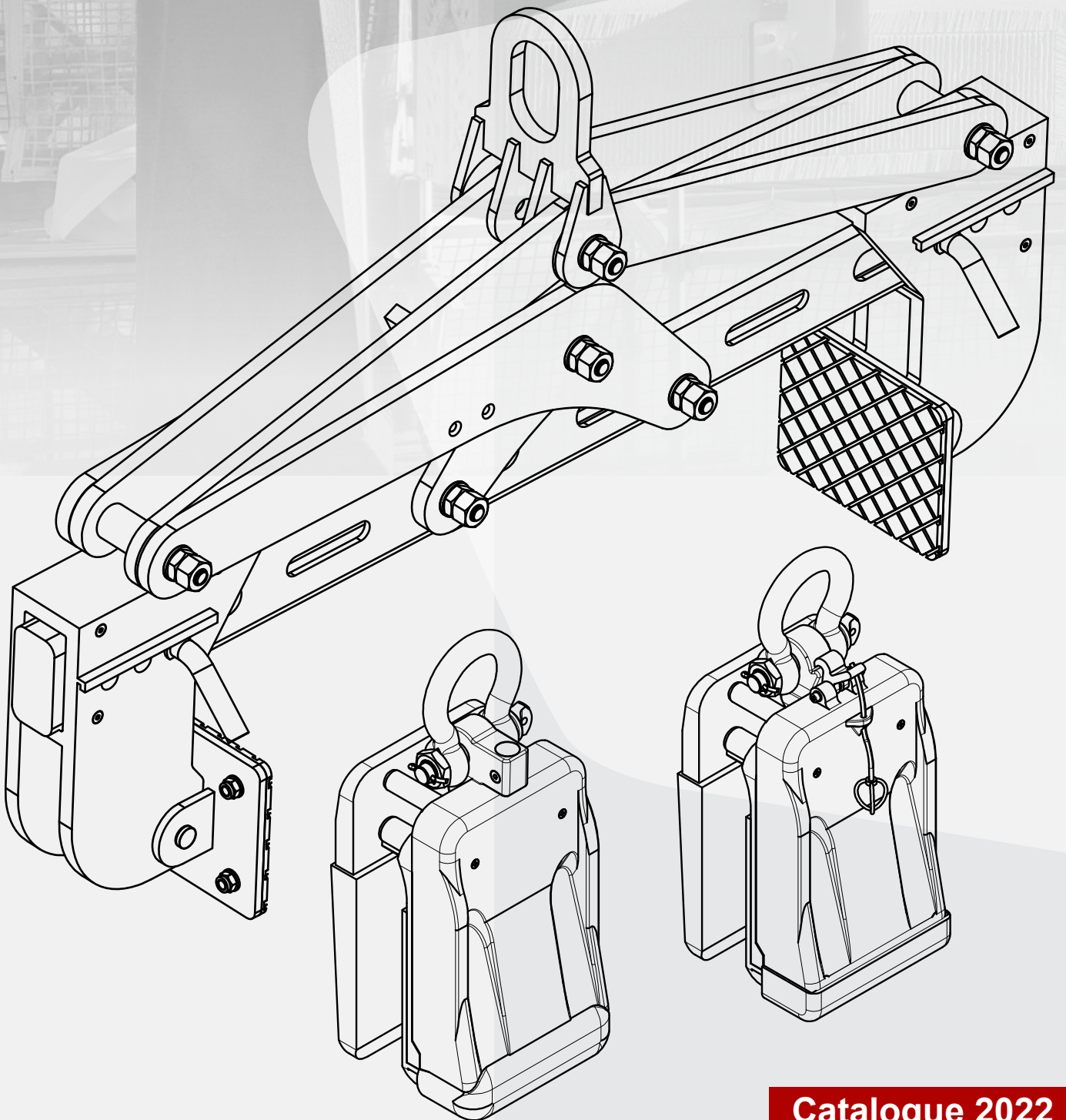

AARDWOLF SLAB LIFTERS

- 001 Slab Lifter Automatic
- 002 Aardwolf Slab Lifter
- 003 Aardwolf Glass Lifter

SLAB LIFTERS

- 001 Scissor Clamp Lifters
- 002 Horizontal Stone Lifting Clamps
- 003 Versa Block Clamps
- 004 Monument Clamps /s Lifters
- 005 Horizontal Stone Lifting Clamps
- 006 Barrier Lifters
- 007 Double Barrier Lifter
- 008 Billet Lifter

DRUM LIFTERS

- 001 Drum Clamp

BRICK LIFTERS

- 001 Brick Grabs Lifter
- 002 Hydraulic Brick Scissor Grab

ROCK LIFTERS

- 001 Rock Lifter Grapples
- 002 Aardwolf Stone Grapple

PIPE LIFTERS

- 001 Concrete Pipe Lifters 00
- 002 Pipe Handling Attachment 00
- 003 Round Bar Lifter 00

LOAD HANDLING ATTACHMENTS

- 001 Spreader Beams
- 002 Pallet Crane Fork

SLAB BUNDLE HANDLER

- 001 Glass Bundle Handler
- 002 Slab Bundle Handlers

STONE CARRYING HAND CLAMPS

- 001 Stone Panel Carriers
- 002 Carry Clamps for Sheet Material
- 003 Stone & Curb Placement Clamp
- 004 Stone Kerb Clamp

HAND VACUUM CUPS

- 001 Hand Vacuum - Cup Lifter
- 002 Oval Hand Vacuum-Cup Lifter
- 003 Hand Vacuum - Cup Lifter HVC
- 004 Double Suction Cup
- 005 Triple Suction Cup

CARGO LASHINGS & SLINGS

- 001 Endless Webbing Slings
- 002 Ratchet Tie Downs

BUY THE ORIGINAL
BUY AARDWOLF

SLAB LIFTER AUTOMATIC



W.L.L:
1200
kg



Aardwolf offers a new version of its patented Aardwolf Slab Lifters. The new Aardwolf Slab Lifters Automatic have an integrated auto-lock, unlock mechanism (patent pending), which allows the clamp to automatically grip slabs on pick-up and release the slabs on set down. In many situations, these make moving and handling of slabs safer and more convenient.

- Auto-lock and unlock, grip and release stone slabs automatically.
- The slab is easily engaged via the jaws of the lifter.
- The heavier the load the tighter the grip.
- Lift the packed slabs out of racks and shipping containers easier.
- Stone panels can be placed close to the wall.

AL30AWJ



AL50A



AL60A



AL75A



PRODUCT CODE	AL30AWJ		AL50A		AL60		AL75	
Grip range	0-30 mm	0 - 1.2 in	10-50 mm	0.4 - 2 in	15-60 mm	0.6 - 2 in	30-75 mm	1 - 3 in
Net weight	20.6 kg	45 lb	19 kg	42 lb	25 kg	55 lb	25 kg	55 lb

THE MOST TRUSTED LIFTERS

AARDWOLF SLAB LIFTERS



W.L.L:
1200
kg

The patented Aardwolf Slab Lifters are an accessory for lifting and moving slab-form loads. The Aardwolf Slab Lifters incorporate a spring-loaded latch that automatically releases the lifter from the slab once the slab has been fully lowered to the ground. These make the process of lifting and lowering of slabs a one man operation.

- An accessory for lifting and moving slab-form loads.
- Requires only a small movement of the slab to engage and grip the slab.
- Ideal for construction work.



PRODUCT CODE	AL30		AL50		AL60		AL75	
Grip range	0-30 mm	0 - 1.2 in	10-50 mm	0.4 - 2 in	15-60 mm	0.6 - 2 in	30-75 mm	1 - 3 in
Net weight	16.3 kg	36 lb	19 kg	42 lb	25 kg	55 lb	25 kg	55 lb

AL50B

REAL AARDWOLF

The Aardwolf Slab Lifter 50 Type B is modified from the Aardwolf Slab Lifter 50. The danger of using any lifter for lowering panels into place on multi-storey buildings is that the load could be lowered onto scaffolding or become fouled by obstructions, which could cause the lifter to lose its load. The over-center lever and support bracket are designed to be used with the Slab Lifter 50 Type B, which prevents the lifter from dropping its load in such an event.

- **Versatile:** Ideal for construction work. Because the clamping mechanism is to the front of the slab, it allows panels to be placed close against walls
- **Secure:** The Aardwolf clamps grip slabs firmly
- The Aardwolf Slab Lifter 50 Type B has a force-multiplying factor of approximately 2.5:1

PRODUCT CODE	AL50B	
Grip range	10 - 50 mm	0.4 - 2 in
Working load limit	1200 kg	2646 lb
Net weight	24 kg	53 lb

SLAB LIFTER 50 TYPE B



AL30AWJH

REAL AARDWOLF

The Aardwolf Glass Lifter AL30AWJH is a unique lifting device for glass. This clamp enables cranes and forklift booms to lift glass sheets vertically from a racking system.

The advantage is that it only requires a small gap between two glass sheets to set down at the top of one sheet and grip it.

Furthermore, its robust structure makes the clamp capable of handling glass sheets weighing up to 1200kg.

PRODUCT CODE	AL30AWJH	
Grip range	0 - 30 mm	0 - 1.2 in
Working load limit	1200 kg	2646 lb
Net weight	21.4 kg	47 lb

AARDWOLF GLASS LIFTER



SCISSOR CLAMP LIFTERS

SLAB LIFTERS



The Aardwolf Scissor Clamp Lifters are equipped with a rubber contact pad for the safe handling of materials. By means of a gravity controlled locking latch, the clamp automatically grips and releases the materials. Suitable for lifting marble and granite slabs, tombstones, concrete barriers, curbs (kerbs) and median walls.

- Auto locks and unlocks.
- Long-lasting, high friction replaceable Polyurethane gripping pads.
- Protective rubber-lined bar prevents the material from chipping.



PRODUCT CODE	ASL-105		ASL-125		ASL-200		ASL-300		ASL-450	
Grip range	0-105mm	0 - 4 in	0-125mm	0-5 in	50-200mm	2-8 in	150-300mm	6-12in	300-450mm	12-18in
Working load limit	750 kg	1653lb	750 kg	1653lb	1000 kg	2204lb	1500 kg	3307lb	2000 kg	4410lb
Net weight	24 kg	53 lb	29 kg	64 lb	47 kg	104 lb	48 kg	106 lb	85 kg	187 lb

HORIZONTAL STONE LIFTING CLAMPS

SLAB LIFTERS

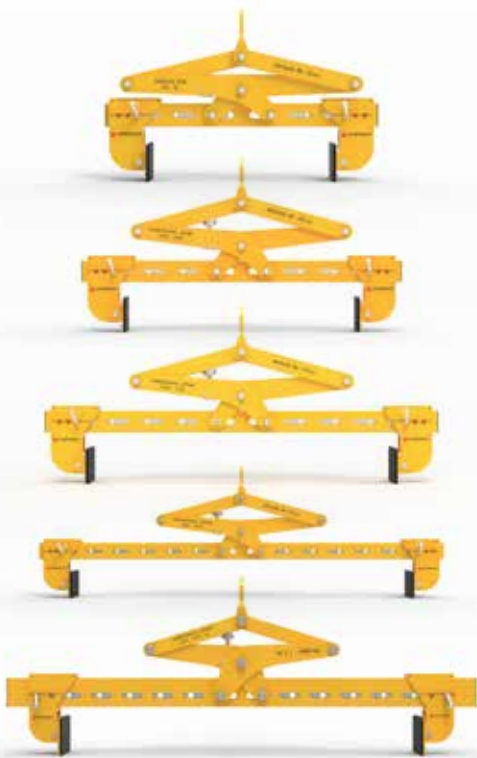

For lifting and moving of concrete blocks and natural stone. Long-lasting, high friction replaceable Polyurethane gripping pads protect load surfaces against damage. Suitable for use on cranes or forklift booms. Clamp jaws are gravity controlled. They open automatically on every second lift and close on every second lift.

- Adjustable jaw opening width.
- A large gripping range, making it suitable for a wide range of applications.
- Long-lasting, high friction replaceable Polyurethane gripping pads.
- Lifting eye for attaching to a crane hook.
- Auto locks and unlocks the load.

PRODUCT CODE	AHLC-2010-4T	
Grip range	300 - 2010 mm	12 - 79 in
Working load limit	4000 kg	8818 lb
Net weight	228 kg	503 lb

PRODUCT CODE	AHLC-730		AHLC-1050		AHLC-1370		AHLC-2010	
Grip range	280-730mm	11-28in	280-1050mm	11-41in	280-1370mm	11-54in	280-2010mm	11-79in
Working load limit	1500 kg	3307 lb	1500 kg	3307 lb	1500 kg	3307 lb	1500 kg	3307 lb
Net weight	112 kg	247 lb	121 kg	267 lb	124 kg	273 lb	137 kg	302 lb

DOUBLE **ADBL-2000** BARRIER LIFTER

SLAB LIFTERS

The Aardwolf Double Barrier Lifter is unique designed for lifting and moving heavy/long materials that do not deform or break, such as concrete barriers, granite slabs, sandstone blocks in a safe, easy, and efficient manner. The material contact surface is protected by the clamping rubber covering. The clamp is gravity controlled, which opens when rested and closes when lifted.

- Auto locks and unlocks.
- Protective rubber-lined bar prevents the material from chipping.
- Equipped with guide legs for balancing the material during the lowering process in an exact manner.
- Vulcanized rubber pads.



Grip range	
155 - 250 mm	6.1 - 9.8 in
Working load limit	
2000 kg	4408 lb



VERSA BLOCK CLAMPS

AVBC-600 & AVBC-1100

The Versa Block Clamps are made for lifting and moving concrete blocks, rubber tires, drums or other materials. The clamps consist of two sliding pads that can be adjusted to the desired widths and they are locked by a locking latch on each side. The Versa Block Clamps are a multipurpose solution when fitted with different jaws to grab the different material types, whether square or curved shapes. These jaws can be easily changed and reversed to allow for picking up objects from the inside face or inside out.

- Handles heavy loads with different capacities.
- Grips and releases the load automatically.
- The jaw width is simple and easy to adjust.
- The rubber jaws protect loads from being damaged.
- Optional jaws for different material shapes.
- Lifting eye allows for easy hook attachment.

PRODUCT CODE	AVBC-600		AVBC-1100	
Grip range	100 - 610 mm	4 - 24 in	150 - 1100 mm	6 - 43 in
Working load limit	1200 kg	2646 lb	3000 kg	6614 lb
Net weight	50 kg	110 lb	161 kg	355 lb

MONUMENT CLAMPS / LIFTERS

SLAB LIFTERS

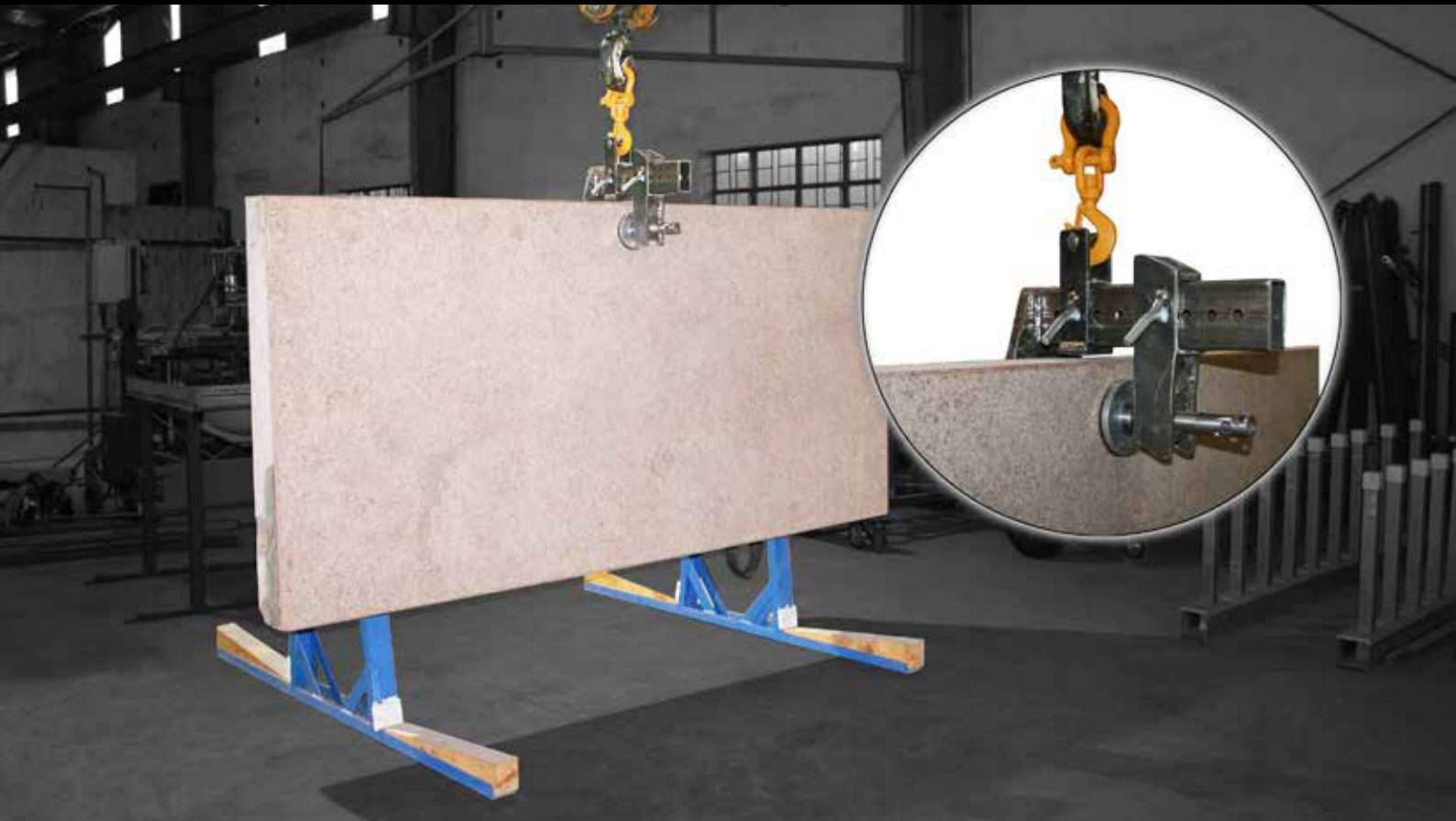

Works with any lifting device. The Aardwolf Monument/Lifter (Automatic) is ideal for lifting and setting concrete, stone and marble building fascia. It is useful for moving and setting heavy or awkward retaining wall blocks and slabs. The slim profile allows it to set material in tight places. The clamping jaw and the center of gravity are easily and quickly adjustable by means of the locking pins. The jaws of the lifter are lined with vulcanized rubber to ensure a safe and non-marking grip. The clamps are gravity controlled, which open when rested and close when lifted.

GPM1000A



GPM1500-A



GPM1000

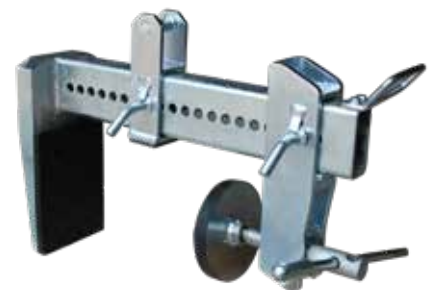

PRODUCT CODE	GPM1000A		GPM1500-A		GPM1000	
Grip range	20 - 300 mm	1 - 12 in	20 - 300 mm	1 - 12 in	0 - 407 mm	0 - 12 in
Working load limit	1000 kg	2204 lb	1500 kg	3307 lb	1000 kg	2204 lb
Net weight	33 kg	73 lb	52 kg	115 lb	33 kg	73 lb

BARRIER LIFTERS

SLAB LIFTERS



The Aardwolf Barrier Lifters are the solution for lifting and moving heavy granite slabs, sandstone blocks and concrete barriers in a safe, easy and efficient manner. The contact surface of the material is protected by the rubber covering the clamp. These clamps are gravity controlled, which opens when rested and closes when lifted.

- Auto locks and unlocks.
- Long-lasting, high friction replaceable Polyurethane gripping pads.
- Protective rubber-lined bar prevents the material from chipping.

ABL-255/2000



ABL-255/3000



ABL-360/5000



PRODUCT CODE	ABL-255/2000		ABL-255/3000		ABL-360/5000	
Grip range	100 - 255 mm	4 - 10 in	100 - 255 mm	4 - 10 in	100 - 360 mm	4 - 14.2 in
Working load limit	2000 kg	4408 lb	3000 kg	6614 lb	5000 kg	11023 lb
Net weight	84 kg	185 lb	146 kg	322 lb	426 kg	939 lb

BILLET LIFTER

BL59

The Aardwolf Slab Billet Clamp utilizes gravity to grip and release materials. The machine is used for handling marble and granite slabs from the billet saw.

- A gravity hoisting device is used to control the opening and closing of the clamp
- The clamp has one movable jaw, which is lined with rubber
- The clamp uses the weight of the load to generate a closing force and the friction generated by the clamping force to clamp the slabs

Grip range	5 - 60 mm	0.2 - 2 in
Working load limit	200 kg	441 lb
Net weight	16 kg	35 lb

SLAB LIFTERS



DRUM CLAMP

ADC-572

The Drum Clamp 572 (ADC-572) is specially designed for lifting and moving drums in a vertical position. Useful and easy to operate, the ADC-572 is a perfect solution for drum industries. The clamp is automatically close when lifted and open when rested by the latch locking. Clamping jaws are designed curved surfaces to make it is fit with a diameter of drums. It works great with a crane or forklift boom to transport drums. The ADC-572 is manufactured with high resistance steel alloy material so that it is strength and durability.

- Compact design and sturdy constructure by the steel alloy
- Lightweight for easy handling in tight spaces between other drums
- Integrated automatically locking latch mechanism
- Quick and gentle loading to transport drums
- Low cost to maintenance

Grip range	572 mm	22 in
Working load limit	500 kg	1102 lb
Net weight	20 kg	44 lb

DRUM LIFTERS



BRICK GRABS LIFTER

BRICK LIFTERS



ABGL-1800



The Brick Grabs Lifter is made to mechanically lift, move and place various bricks size without the need to hook up additional hydraulics or electrical for it to operate. Clamping jaws are equipped with durable rubber to hold tight materials. This device can be used with different types of cranes such as overhead cranes, mobile cranes, truck-mounted cranes or forklifts... in the factory or on construction site. The load does not have to be palletized and can be handled from inconvenient positions with limited space. The grab has adjustable plunge depth - convenient when you handle loads of varying heights.

- Fully automatic mechanism.
- Adjustable plunge depth for different pack sizes.
- Profiled hooks for attachments.
- Time-saving, labor-saving, and cost-saving.



HYDRAULIC BRICK SCISSOR GRAB

HBSG1500

The Hydraulic Brick Scissor Grab is designed for the sand-lime brick industry.

The robust construction is able to lift and rotate the brick using a hydraulic control valve. The hydraulic brick clamp provides effective transport for sand-lime brick.

- High strength welded steel construction for maximum strength and durability.
- Moves palletized items efficiently and safely into different production environments.

PRODUCT CODE	ABGL-1800		HBSG1500	
Grip range	800 - 1100 mm	31 – 43 in	0 – 1200 mm	0 – 47 in
Working load limit	1800 kg	3968 lb	1500 kg	3307 lb
Net weight	561 kg	1237 lb	950 kg	2095 lb

ROCK LIFTERS



ARL-800



ARL-1200



ASG



ROCK LIFTER GRAPPLE

The Rock Lifter Grapple is an attachment that makes moving and setting large rocks and boulders a snap. Designed for the landscape contractor, stonemason, or anyone else who works regularly with rocks and boulders. The Rock Lifter Grapple is an efficient solution to work faster, better and with less labor.

- High tensile steel welded construction.
- Simple and reliable operation with minimal maintenance.
- A safer and easy way to move large rocks.
- Suitable for handling boulders and stones of almost all shapes.
- The greater the weight the harder the grip of the tongs.

STONE GRAPPLE

Once the bolder is set down, the stone grapple's internally-housed actuator allows the operator to lift the stone grapple from the bolder, ready for the next lift cycle

- 3-point design.
- Lifts irregular shaped objects or debris.
- Quick load cycles.

**QUICK
LOAD
CYCLES**

PRODUCT CODE	ARL-800		ARL-1200		ASG	
Grip range	350 - 800 mm	14 - 31 in	600 - 1200 mm	24 - 47 in	350 - 1200 mm	14 - 47 in
Working load limit	750 kg	1653 lb	1500 kg	3307 lb	2000 kg	4408 lb
Net weight	119 kg	262 lb	354 kg	780 lb	165 kg	364 lb

CONCRETE PIPE LIFTER



Fast, efficient, flexible, smart and fully automatic, the Aardwolf mechanical lifters are designed to safely lift concrete pipes. The lifter does not require additional hydraulics. The operator is able to use the pipe lifter to grab, lift and move pipes without assistance. The narrow profile allows for the easy installation of concrete pipes into tight trenches.

- Auto locks and unlocks a load.
- Vulcanized rubber pads.
- Durable powder-coated finish.

ACPL750



ACPL1500



ACPL2500



PRODUCT CODE	ACPL750		ACPL1500		ACPL2500	
Grip range	400 - 500 mm	15 - 20 in	500 - 750 mm	20 - 29 in	750 - 1000 mm	29 - 39 in
Working load limit	750 kg	1653 lb	1500 kg	3307 lb	2500 kg	5511 lb
Net weight	150 kg	331 lb	226 kg	498 lb	564 kg	1243 lb

PIPE HANDLING ATTACHMENT



PHA4000

- **Grip range:** 300- 1200 mm | 12 - 47 in
- **Pipe length:** 2500 mm | 98.4 in
- **Working load limit:** 4000 kg | 8818 lb

Faster, smarter, more efficient, flexible and fully automatic features enable the Pipe Handling Attachment to safely lift concrete pipes. No hydraulic power supply, slings, chains or manual assistants are needed during the lifting process. The narrow profile allows the easy installation of concrete pipes into tight trenches. By means of the clamping mechanism, the pipes are tightly held to enhance accurate material placement. Users are not required to pick up and put down the pipes during the lifting operation. Thus, this device works in an absolutely secure and safe manner.

ROUND BAR LIFTER

RBL305

The Round Bar Lifter 305 is designed for clamping and lifting steel pipes and steel tubes. It is fast, efficient, flexible and fully automatic, the RBL305 is ideal for work in the factory or on construction sites. It is equipped with an auto-locking latch mechanism, and it needs no electric or hydraulic power supply. The RBL305 can be used with overhead crane or forklift boom to pick and place materials.

- Handling long steel pipes and tubes, especially for steel pipe assembly system. Made from durable steel material.
- Sturdy and safe construction.

- **Grip diameter range:** 200 - 305 mm | 8 - 12 in
- **Working load limit:** 320 kg | 706 lb



ROUND BAR LIFTER

RBL200

With faster, smarter, more efficient, flexible and fully automatic features, The Round Bar Lifter 200 is designed to safely lift steel bars and tubes. This device is equipped with an auto-locking latch mechanism lead with no hydraulic power supply, slings or chains needed. The operator is able to use this device to grab, lift and move pipes without assistance.

- **Grip diameter range:** 180 - 200 mm | 7 - 8 in
- **Working load limit:** 150 kg | 331 lb



PALLET CRANE FORK SPREADER BEAM

LOAD HANDLING ATTACHMENTS

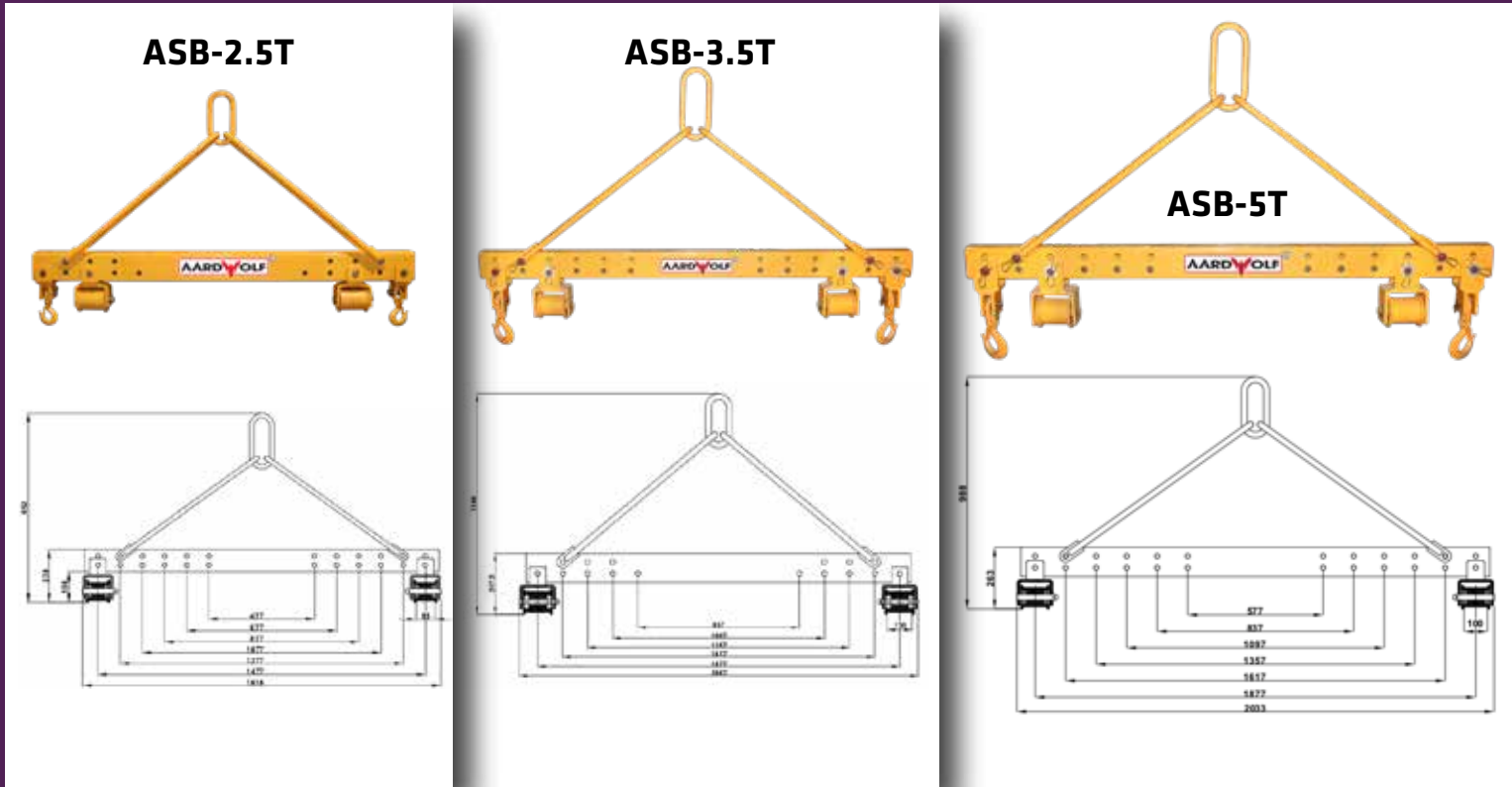

Specifically designed for the stone industry. The Spreader Beam, in combination with endless slings, is an invaluable piece of equipment where the stone is required to be rolled over. The slings are suspended on crowned aluminum rollers. This makes turning the load in the sling easier. The rollers will handle up to 90mm wide slings. The swivel hooks can be used in place of rollers.

- Adjustable lifting points.
- Handle both wide and unbalanced loads.
- It includes swivel hooks.



PALLET CRANE FORK **APCF**

Aardwolf Pallet Crane Fork offers a flexible lifting solution for loading, unloading, handling and transporting heavy materials within production environments. Aardwolf Pallet Crane Fork is a crane attachment engineered to optimize efficiency for overhead lifting for material handling systems.

The Pallet Crane Fork is especially helpful to maximize efficiency in production environments with narrow aisles or for areas that may be inaccessible to forklifts. It becomes a multitasking lifter for the handling of palletized and packaged goods with capacity up to 2500kg.

- High strength welded steel construction for maximum strength and durability.
- Moves palletized items efficiently and safely into different production environments.

PRODUCT CODE	ASB-2.5T		ASB-3.5T		ASB-5T		APCF	
Working load limit	2500 kg	5511 lb	3500 kg	7716 lb	5000 kg	11023 lb	2500 kg	5511 lb
Net weight	46 kg	101 lb	73 kg	161 lb	105 kg	231 lb	242 kg	534 lb

SLAB BUNDLE HANDLERS



GLASS BUNDLE HANDLER

GBH01

The Glass Bundle Handler is a crane attachment used for lifting bundles of glass from closed top containers. It is specially designed to lift and move glass bundles securely and to increase efficiency and worker safety with improved load handling. With the addition of a Glass Bundle Handler, your existing crane can be used to perform many of the functions generally associated with a forklift truck. It is used most efficiently on gantry cranes with a 5-tonne capacity or greater. The Glass Bundle Handler can also be used on mobile cranes.

SLAB BUNDLE HANDLER

3 Tons SBH01 & 5 Tons SBH02

As a crate extraction unit, the Slab Bundle Handler is a crane attachment used for lifting crated slabs of marble and granite from closed top containers. Designed to lift stone slab bundles securely and to increase efficiency and worker safety with improved load handling. With the addition of a Slab Bundle Handler, your existing crane can be used to perform many of the functions generally associated with a forklift truck. It is used most efficiently on gantry cranes with a 3-tonne / (5-tonne) capacity or greater. The Slab Bundle Handler can also be used on mobile cranes.



PRODUCT CODE	GBH01		SBH01		SBH02	
Working load limit	2500 kg	5511 lb	3000 kg	6614 lb	5000 kg	11023 lb
Net weight	2030 kg	4475 lb	2000 kg	4408 lb	3200 kg	7055 lb

SAFELY LIFT AND CARRY PANNELS WITH A COMFORTABLE POSTURE

STONE CARRYING HAND CLAMPS



SCC02



SCC03

SCC05



ASKC200

STONE PANEL CARRIERS **SCC02**

The Stone Panel Carrier with Cable is designed for lifting, carrying and moving sheets from building materials that are large, unwieldy and heavy, such as panels of glass, granite, marble, plywood, particleboard, etc.

This device significantly reduces stress and the potential injuries to the fingers, wrists, and back. It also reduces physical fatigue. The Stone Panel Carrier with Cable works by clamping onto the edge of panels, creating a sturdy temporary handle for the workers who are carrying them. It allows tradespeople to lift and move panels with a straight back, thereby avoiding back injuries.

- Finger trigger jaw opening and load release mechanism.
- Constructed of sturdy lightweight aluminum.
- Jaws are continuously self-adjusting.
- High-friction vulcanized rubber gripping pads mounted on both plates protect the surfaces of the materials from being damaged or marred.
- Moulded rubber hand grips.
- Locks onto panels automatically.
- The vice-like grip on panels.

Note:
Sold in pair.

CARRY CLAMPS FOR SHEET MATERIAL **SCC03 & SCC05**

Note: *Sold in pair.*

Carry Clamps for Sheet Material are used in pairs, allowing users to lift and carry panels safely and comfortably. The clamp design utilizes the weight of the sheet material to provide the clamping force. A vulcanized rubber lining on the jaws prevents damage to the surface of the material.

STONE KERB CLAMP **ASKC200**

This two-man block clamp is suitable for a large range of handling applications, such as lifting/handling concrete and granite kerb stone as used in road construction or for heavy building blocks. The center chain can be attached to machines for heavy lifting.

- Powder-coated frame to resist corrosion and rust
- Tilting pads ensure maximum grip

STONE & CURB PLACEMENT CLAMP

SCC04

This two-man block clamp is ideal for installing concrete or stone curbs. Designed to make the work easy and comfortable without pains when working hours are over.

PRODUCT CODE	SCC02		SCC03		SCC04		SCC05		ASKC200	
Grip range	0-52 mm	0-2 in	0-50 mm	0-2 in	100-500mm	4-20in	50-100mm	2-4 in	0-260mm	0-10in
Working load limit	150 kg	331 lb	200 kg	441 lb	200 kg	441 lb	200 kg	441 lb	200 kg	441 lb
Net weight	2 kg	4 lb	6.6 kg	14.6 lb	16.9 kg	37.3 lb	8.3 kg	18 lb	23 kg	51 lb



SCC04

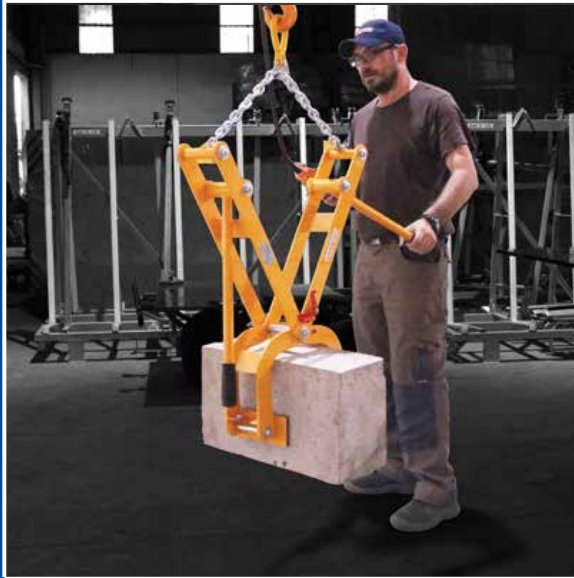

100% HIGH TENACITY POLYESTER

CARGO LASHINGS & SLINGS

CLS1T



CLS2T



CLS3T



RTD1B



RTD2A



ENDLESS WEBBING SLING - 1TON - 2TON - 3TON

RATCHET TIE DOWN 1 - DOWN 2

	CLS1T		CLS2T		CLS3T		RTD1B		RTD2A	
Webbing Width	50 mm	2 in	60 mm	2.4 in	90 mm	3.5 in	25 mm	1 in	50 mm	2 in
Effective/ Strap Length	3000 mm				118 in		3000 mm	118 in	9150 mm	360 in
Working Load Limit	1000 kg	2205 lb	2000 kg	4409 lb	3000 kg	6614 lb	225 kg	500 lb	2500 - 5000 kg	
Net Weight	0.42 kg	0.9 lb	1.14 kg	2.5 lb	1.92 kg	4.2 lb	-	-	5511 - 11023 lb	



FIND YOUR NEAREST AARDWOLF FACTORY SERVICE CENTRE NEAR YOU

WE ARE PROVIDING

SIMPLE, REALIABLE, COST SAVING
AND AWESOME IDEAS FOR YOUR BUSINESS



AUSTRALIA

1/5 Stanton Road, Seven Hills NSW 2147

Tell: 02 9838 8427

www.aardwolfaustralia.com Email: enquiries@aardwolfaustralia.com

BULGARIA Str.Usta Kolio Ficheto 33 Tell: +359 887 933 754

INDIA

Harama Road, Industrial area, Madanganj, Kishangarh, Rajasthan n India
Pin no. 305801 Mob: +91 73000-68444 Tell: +91 9358448474

Web: www.aardwolf.co.in Email: sales@aardwolf.co.in

GERMANY

Schulze-Delitzsche Weg 2, 33175 Bad Lippspringe

Tell: 05252 8382830

USA

19201 South Reyes Avenue, Suite A3 Rancho Dominguez California,

Tell: (562) 553-6050 90221

Web: www.aardwolfusa.com Email: leo@aardwolfusa.com

VIETNAM

1B, An Phu, Thuan An City, Binh Duong Province, Vietnam

Tell: +84 931 707 793

Web: www.aardwolf.com.au Email: info@aardwolf.com.au

AARDWOLF PRODUCT VIDEO
www.youtube.com/user/AardwolfGroup

